

PHASED STRATA PLAN OF LOT 'C' OF SECTION 32, BLOCK 5 NORTH, RANGE 1 WEST, PLAN 74360, NEW WESTMINSTER DISTRICT
INTEGRATED SURVEY AREA N91 MUNICIPALITY OF SURREY, B.C.

STRATA PLAN NW 2754
PHASE 1
 DEPOSITED AND REGISTERED IN THE LAND TITLE OFFICE AT NEW WESTMINSTER, B.C. THIS 8th DAY OF APRIL 1988.

SCALE - 1:1000 ALL DISTANCES ARE IN METRES.

REGISTRAR

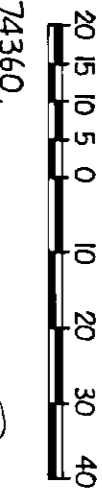

LEGEND GRID BEARINGS ARE DERIVED FROM PLAN 74360. THIS PLAN SHOWS GROUND-LEVEL MEASURED DISTANCES. PRIOR TO COMPUTATION OF U.T.M. CO-ORDINATES, MULTIPLY BY COMBINED FACTOR 0.9995970.

Ref: # AB 56699 to AB 56718

© DENOTES COMMON PROPERTY.

THE ADDRESS FOR SERVICE OF DOCUMENTS ON THE STRATA CORPORATION IS: THE OWNERS, STRATA PLAN NW 2754 101-14861-98th. AVENUE SURREY, B.C.

THE OWNERS, STRATA PLAN NW 2754 101-14861-98th. AVENUE SURREY, B.C.

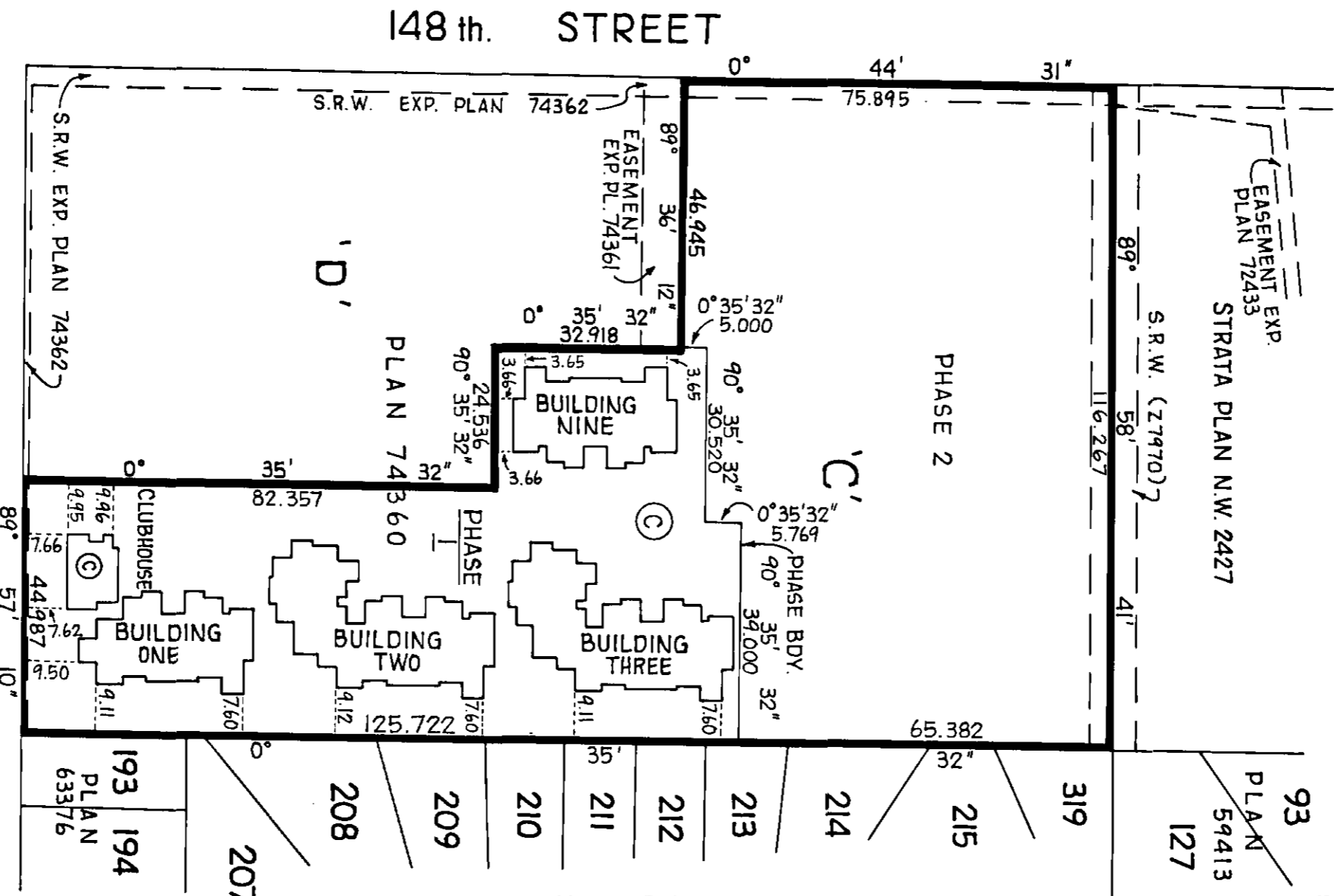

NOTE:
 1.) BUILDINGS 4,5,6,7 AND 8 ARE NOT INCLUDED IN THIS PHASE.
 2.) STRATA LOT NUMBERS 17 TO 42 INCLUSIVE ARE NOT USED IN THIS PHASE.

THIS PLAN LIES WITHIN THE GREATER VANCOUVER REGIONAL DISTRICT

APPROVED AS TO PHASE 1 OF A TWO PHASE STRATA PLAN UNDER THE CONDOMINIUM ACT. DATED THIS 15th DAY OF March 1988.

ISAAC, OSMAN & ASSOCIATES
 B.C. LAND SURVEYORS
 20609 LOGAN AVENUE
 LANGLEY, B.C. V3A 7R3
 PHONE 533-2411

I, A.M. OSMAN, OF LANGLEY, B.C., A BRITISH COLUMBIA LAND SURVEYOR, HEREBY CERTIFY THAT THE 5 BUILDINGS ERCTED ON THE PARCEL DESCRIBED ABOVE ARE WHOLLY WITHIN THE BOUNDARIES OF THAT PARCEL.

FILE 11427 (NU PACIFIC REALTY DEV.LTD.)

DATED AT LANGLEY, B.C. THIS 4th DAY OF FEB. 1988.

FOUNDATION PERIMETER OF BUILDINGS ONE AND TWO

STRATA PLAN N.W. 2754 PHASE I

SCALE - 1:200
ALL DISTANCES ARE IN METRES.
LEGEND
⊙ DENOTES COMMON PROPERTY.



11427

P L A N 7 4 3 6 0

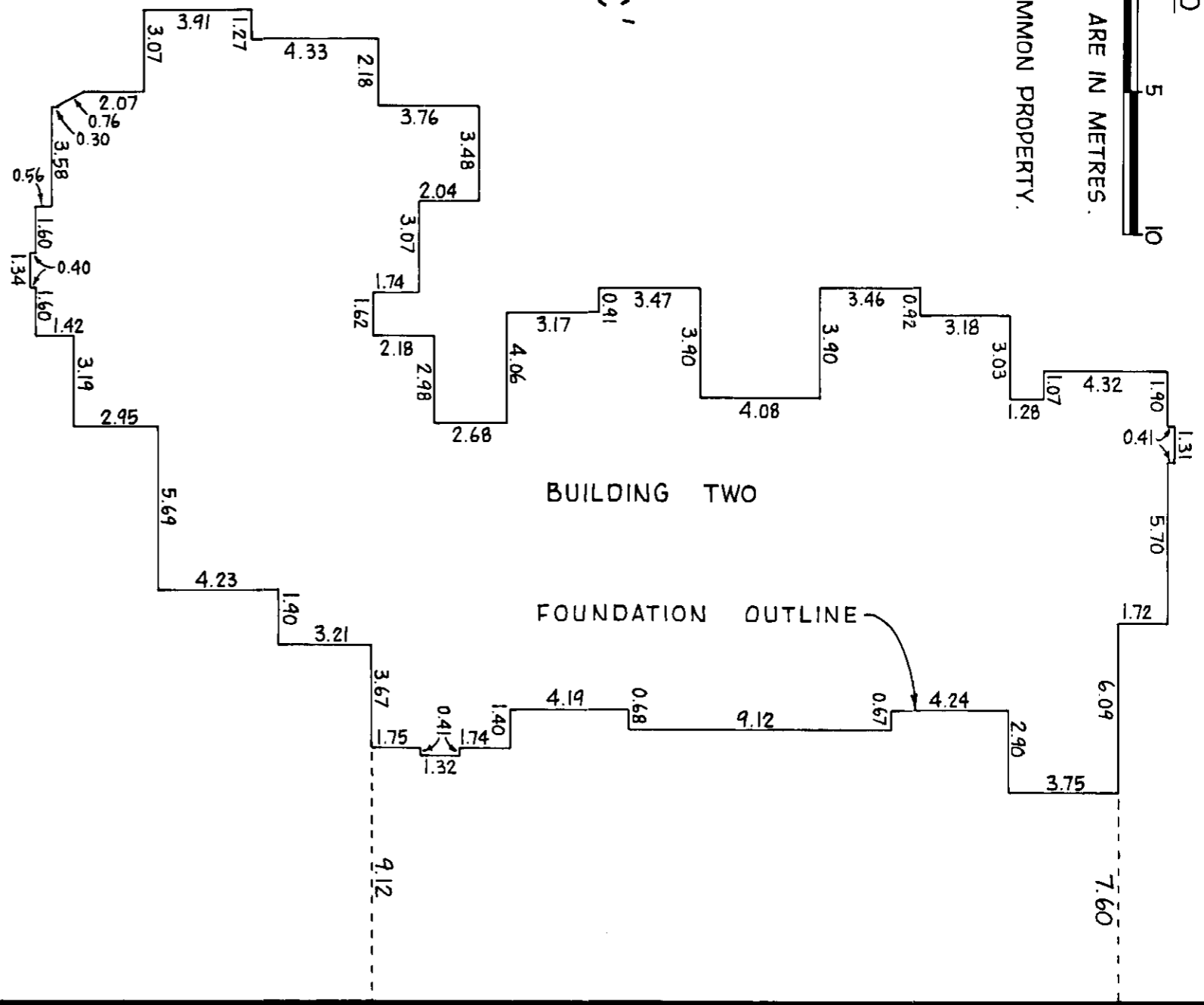
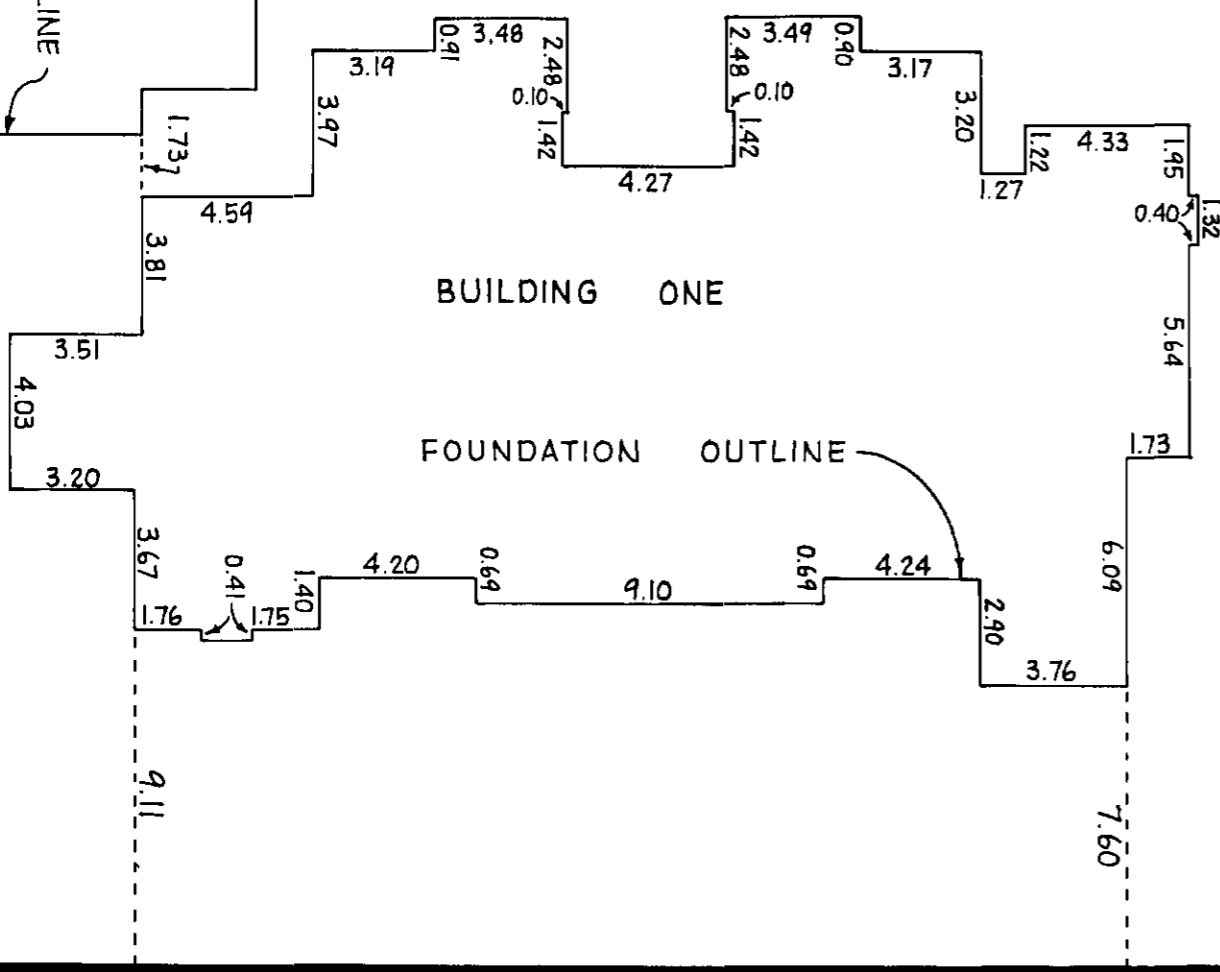
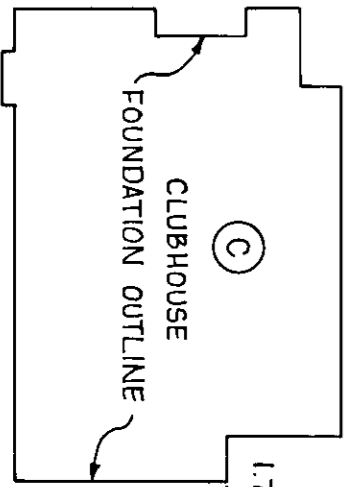

PLAN 193 63376 207 P L A N 208 63376 209 210

9/2/88 *aw*

FOUNDATION PERIMETER OF
BUILDINGS THREE AND NINE

STRATA PLAN N.W. 2754
PHASE I

SCALE - 1 : 200 ALL DISTANCES ARE IN METRES.

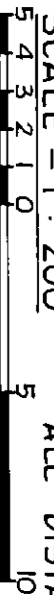

LEGEND

⊙ DENOTES COMMON PROPERTY.

213 PLAN 212 211 63376 210

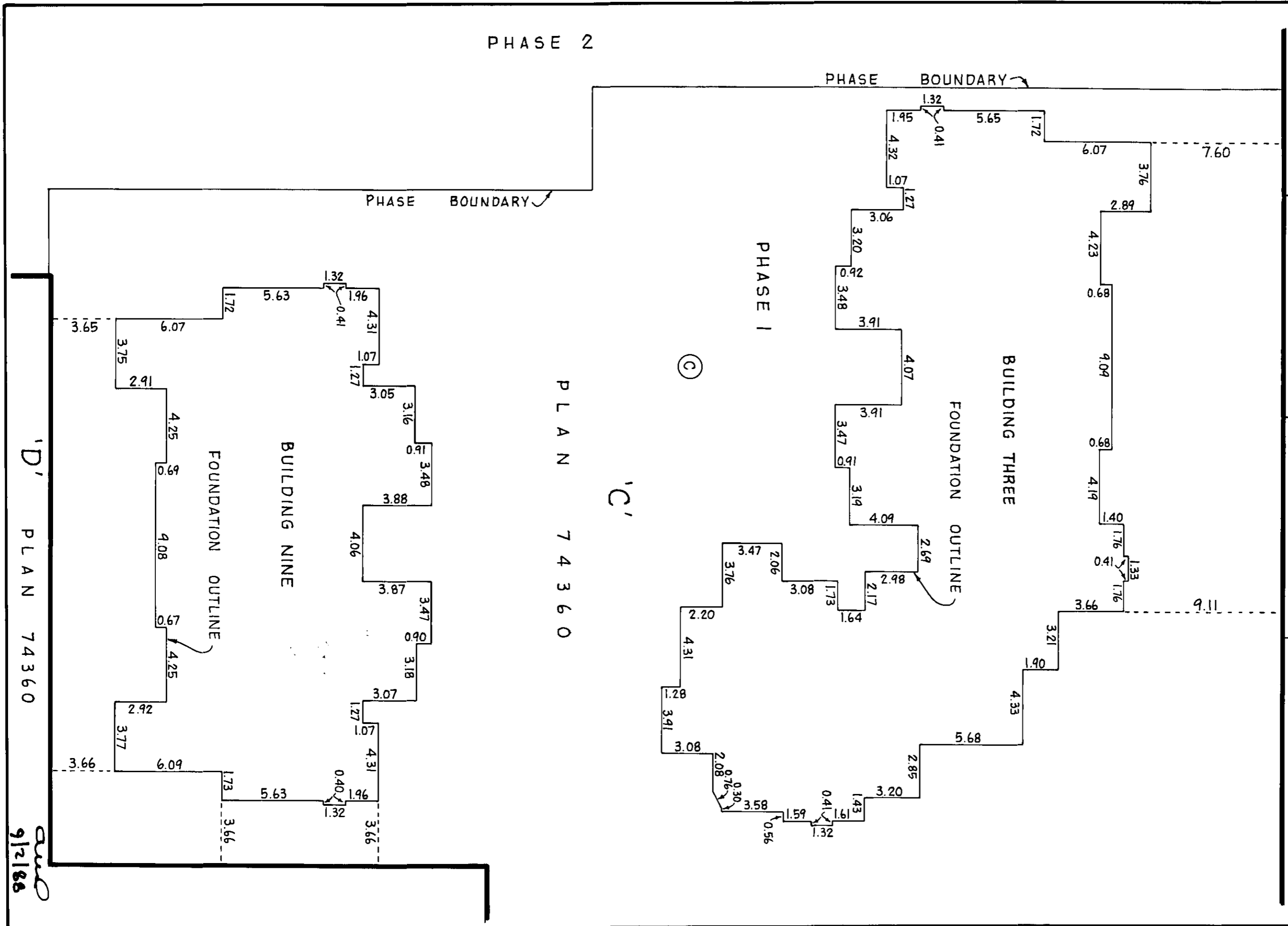

PLAN 74360

'D' PLAN 74360

9/2/88

11427

STRATA PLAN N.W. **2754**
PHASE 1

STRATA LOT No	SHEET No	UNIT ENTITLEMENT	FORM 1 SCHEDULE OF UNIT ENTITLEMENT	FORM 2 SCHEDULE OF INTEREST UPON DESTRUCTION	FORM 3 SCHEDULE OF VOTING RIGHTS	NUMBER OF VOTES
1	5	136	108	108		
2	5	140	111	111		
3	5	138	108	108		
4	5	136	109	109		
5	6	149	118	118		
6	6	136	108	108		
7	6	141	111	111		
8	6	128	113	113		
9	6	137	108	108		
10	6	136	109	109		
11	7	149	118	118		
12	7	136	108	108		
13	7	141	111	111		
14	7	128	113	113		
15	7	137	108	108		
16	7	136	109	109		
43	8	141	118	118		
44	8	141	108	108		
45	8	136	111	111		
46	8	136	113	113		
AGGREGATE		2758	2220			

NOTE : UNIT ENTITLEMENT IS BASED ON HABITABLE AREA.
INTEREST UPON DESTRUCTION IS BASED ON BUILDING VALUE.

ACCEPTED AS TO FORMS 1, 2 AND 3
THIS 7 DAY OF April 1988.

[Signature] SUPERINTENDENT OF REAL ESTATE

STATUTORY DECLARATION

I, THE UNDERSIGNED, DO SOLEMNLY DECLARE THAT :
1.) I, THE UNDERSIGNED, AM THE DULY AUTHORIZED AGENT OF THE OWNER - DEVELOPER.
2.) THE STRATA PLAN IS ENTIRELY FOR RESIDENTIAL USE.
I MAKE THIS SOLEMN DECLARATION CONSCIENTIOUSLY BELIEVING IT TO BE TRUE
AND KNOWING IT IS OF THE SAME FORCE AND EFFECT AS IF MADE UNDER OATH.

[Signature]
AUTHORIZED SIGNATORY for the
AGENT OF THE OWNER - DEVELOPER

OWNER :
NU PACIFIC REALTY DEVELOPMENT
(GUILDFORD) LTD. (INC. # 325818)

[Signature]
AUTHORIZED SIGNATORY

AUTHORIZED SIGNATORY

MORTGAGEE :

[Signature]
NELS GEORGE HANSENSON

[Signature]
WITNESS

[Signature]
Occupation

[Signature]
Address Vancouver, B.C.
V5Y 4H9

DECLARED BEFORE ME AT Vancouver IN THE
PROVINCE OF BRITISH COLUMBIA,
THIS 16th DAY OF MARCH 1988.

[Signature]
A COMMISSIONER FOR TAKING AFFIDAVITS
WITHIN BRITISH COLUMBIA.

MORTGAGEES :
VANCOUVER CITY SAVINGS CREDIT UNION

[Signature]
AUTHORIZED SIGNATORY

[Signature]
AUTHORIZED SIGNATORY
HIGH POINT COURT HOLDINGS LTD. (INCORPORATION
NO. 282956)

[Signature]
AUTHORIZED SIGNATORY

AUTHORIZED SIGNATORY

I, A. M. OSMAN, A BRITISH COLUMBIA LAND SURVEYOR, HEREBY
CERTIFY THAT THE FOUR BUILDINGS SHOWN IN THIS STRATA
PLAN HAVE NOT, AS OF THE 9th. DAY OF FEBRUARY, 1988 BEEN
PREVIOUSLY OCCUPIED. DATED AT LANGLEY, BRITISH COLUMBIA
THIS 9th. DAY OF FEBRUARY, 1988.

[Signature] B.C.L.S.

STRATA PLAN N.W. **2754**

PHASE 1

BUILDING ONE

SCALE - 1 : 200

LEGEND

PT. S.L. DENOTES PART STRATA LOT.
 m² SQUARE METRES.
 L.C.P. LIMITED COMMON PROPERTY.



FIRST FLOOR

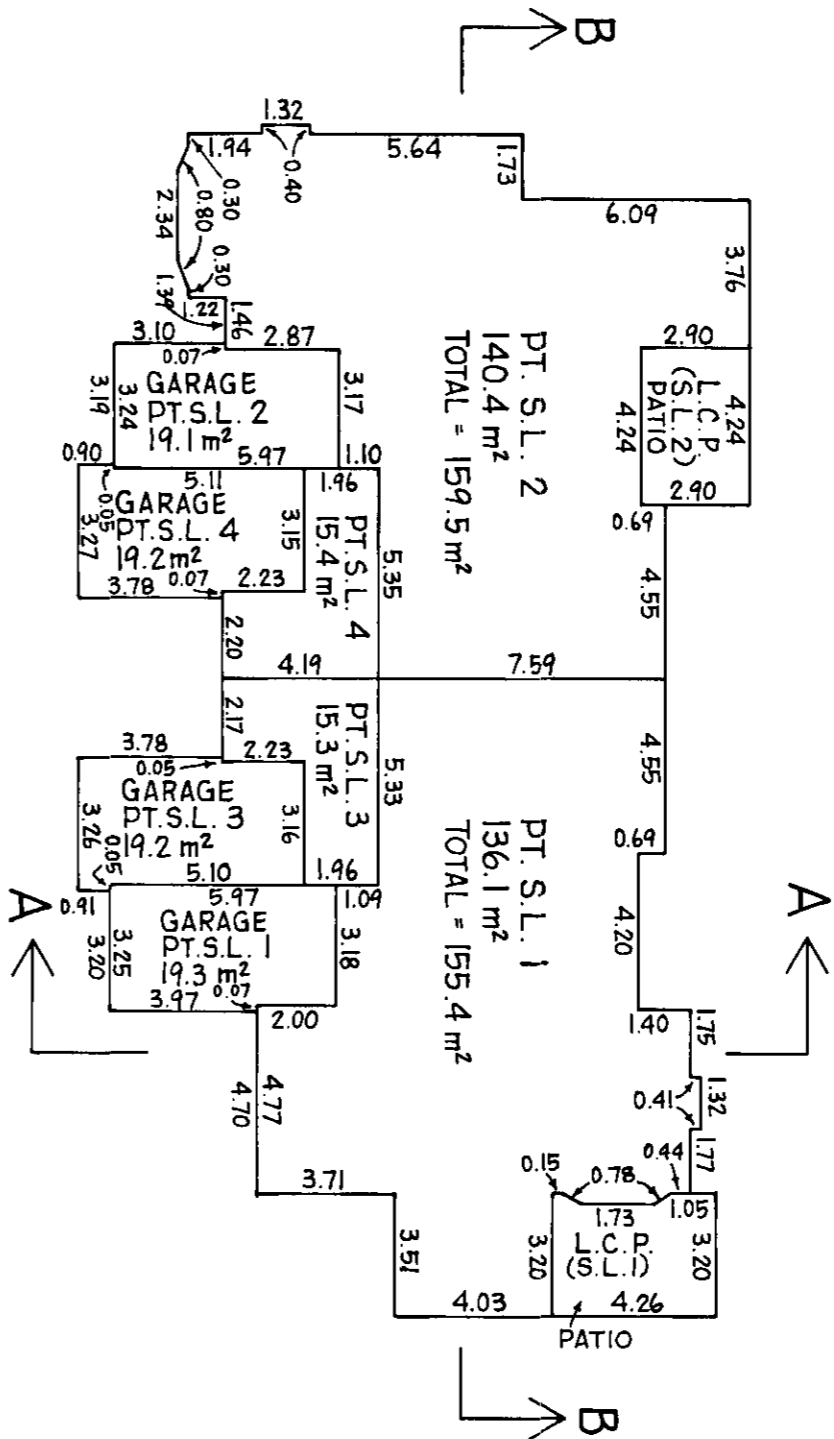

SECOND FLOOR

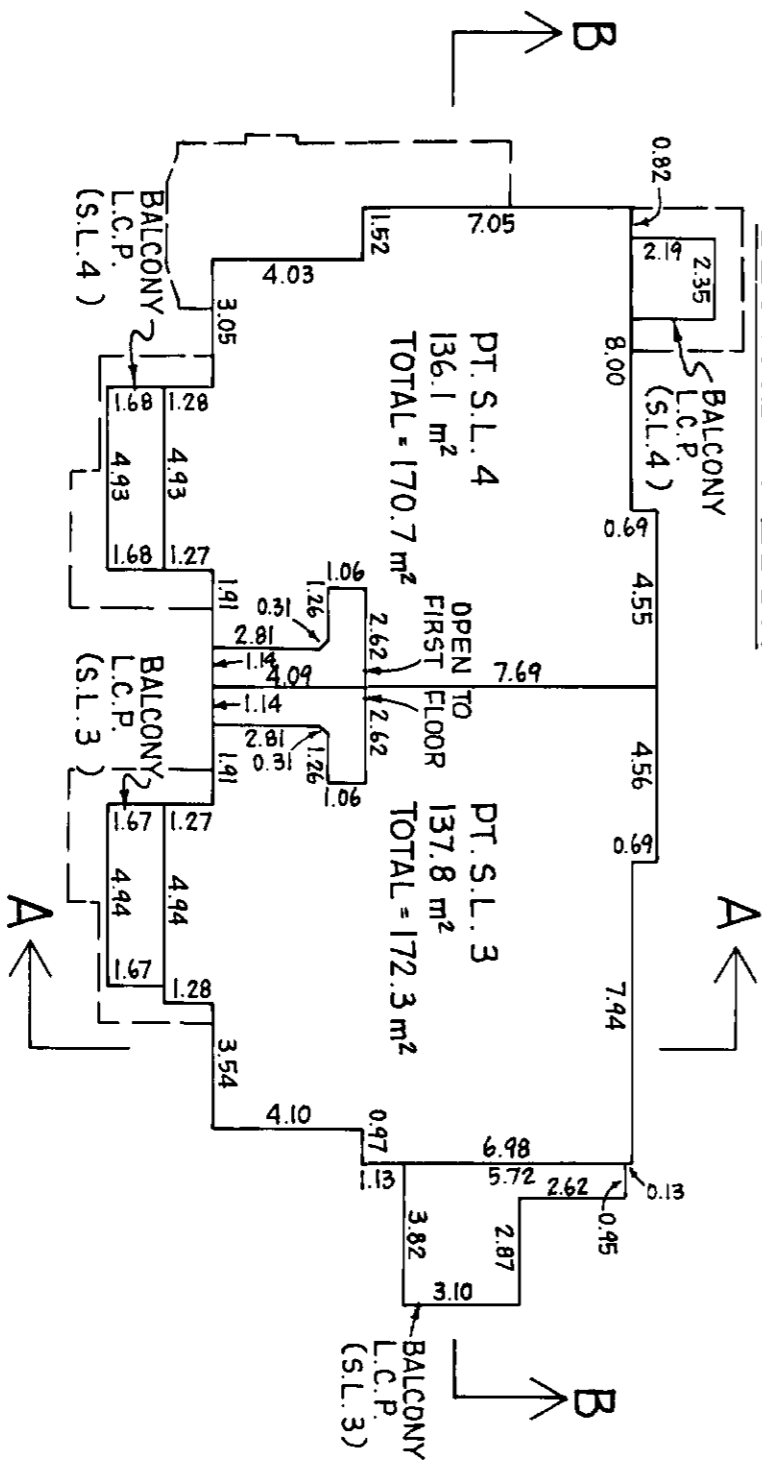

NOTE : DOTTED LINES INDICATE OUTLINE OF FIRST FLOOR.

CIVIC ADDRESSES :

- STRATA LOT 1 - 102-14861-98th. AVENUE, SURREY, B.C.
- " " 2 103 " " " " " "
- " " 3 202 " " " " " "
- " " 4 203 " " " " " "

11427

9/2/88

BUILDING TWO

STRATA PLAN N.W. 2754

PHASE 1

SCALE - 1 : 200

LEGEND

- PT. S.L. DENOTES PART STRATA LOT.
- m² SQUARE METRES.
- L.C.P. LIMITED COMMON PROPERTY.
- © COMMON PROPERTY.

FIRST FLOOR

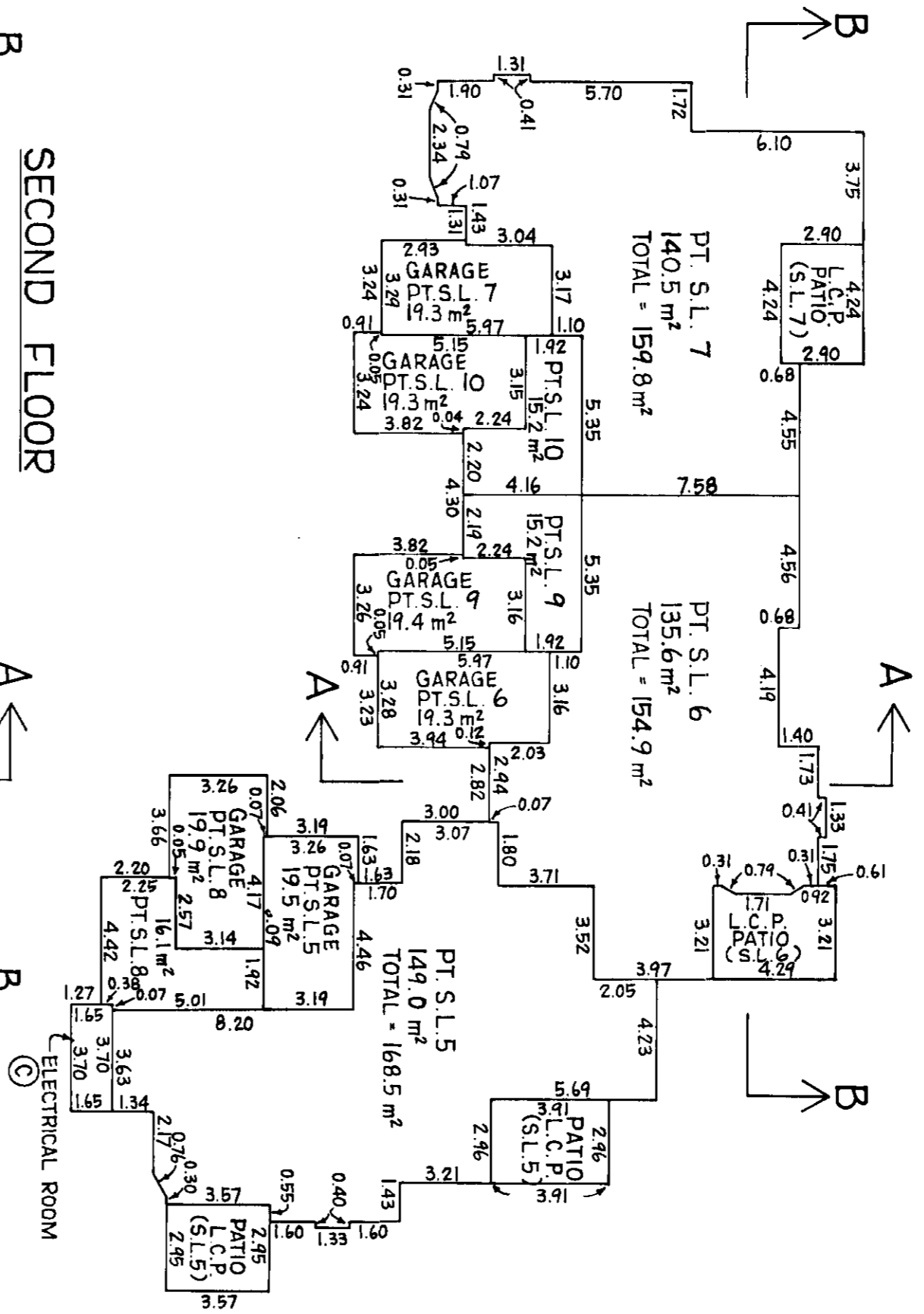

SECOND FLOOR

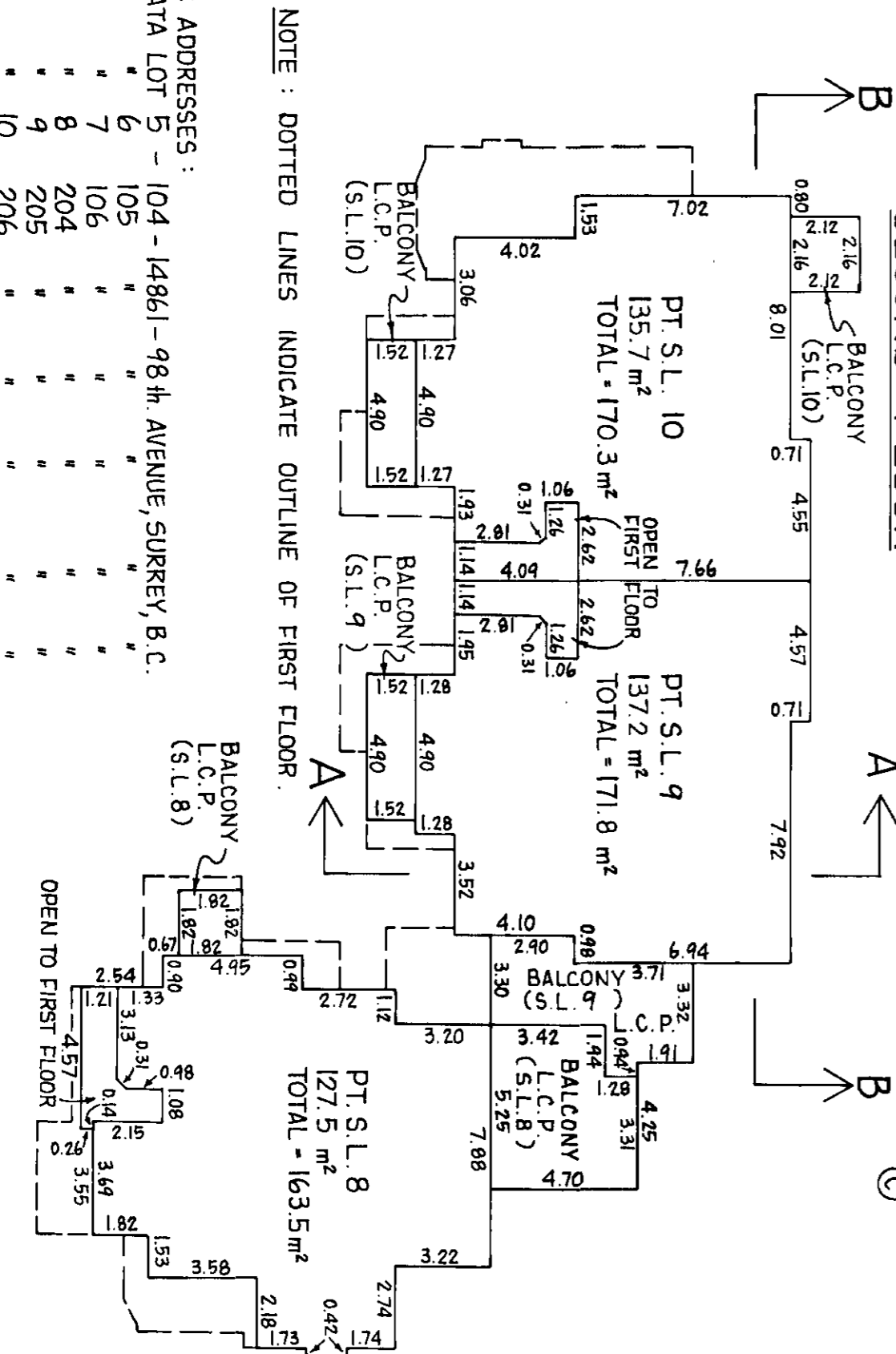

NOTE : DOTTED LINES INDICATE OUTLINE OF FIRST FLOOR.

CIVIC ADDRESSES :
 STRATA LOT 5 - 104 - 14861 - 98th AVENUE, SURREY, B.C.

- " 6 105 " " " " " " "
- " 7 106 " " " " " " "
- " 8 204 " " " " " " "
- " 9 205 " " " " " " "
- " 10 206 " " " " " " "

ang.
 9/2/88

11427

BUILDING THREE

STRATA PLAN NW. 2754

SHEET 1 OF 14 SHEETS

SCALE - 1 : 200

PHASE 1

LEGEND

- PT.S.L. DENOTES PART STRATA LOT.
- m² SQUARE METRES.
- L.C.P. LIMITED COMMON PROPERTY.
- ⊙ COMMON PROPERTY.



FIRST FLOOR

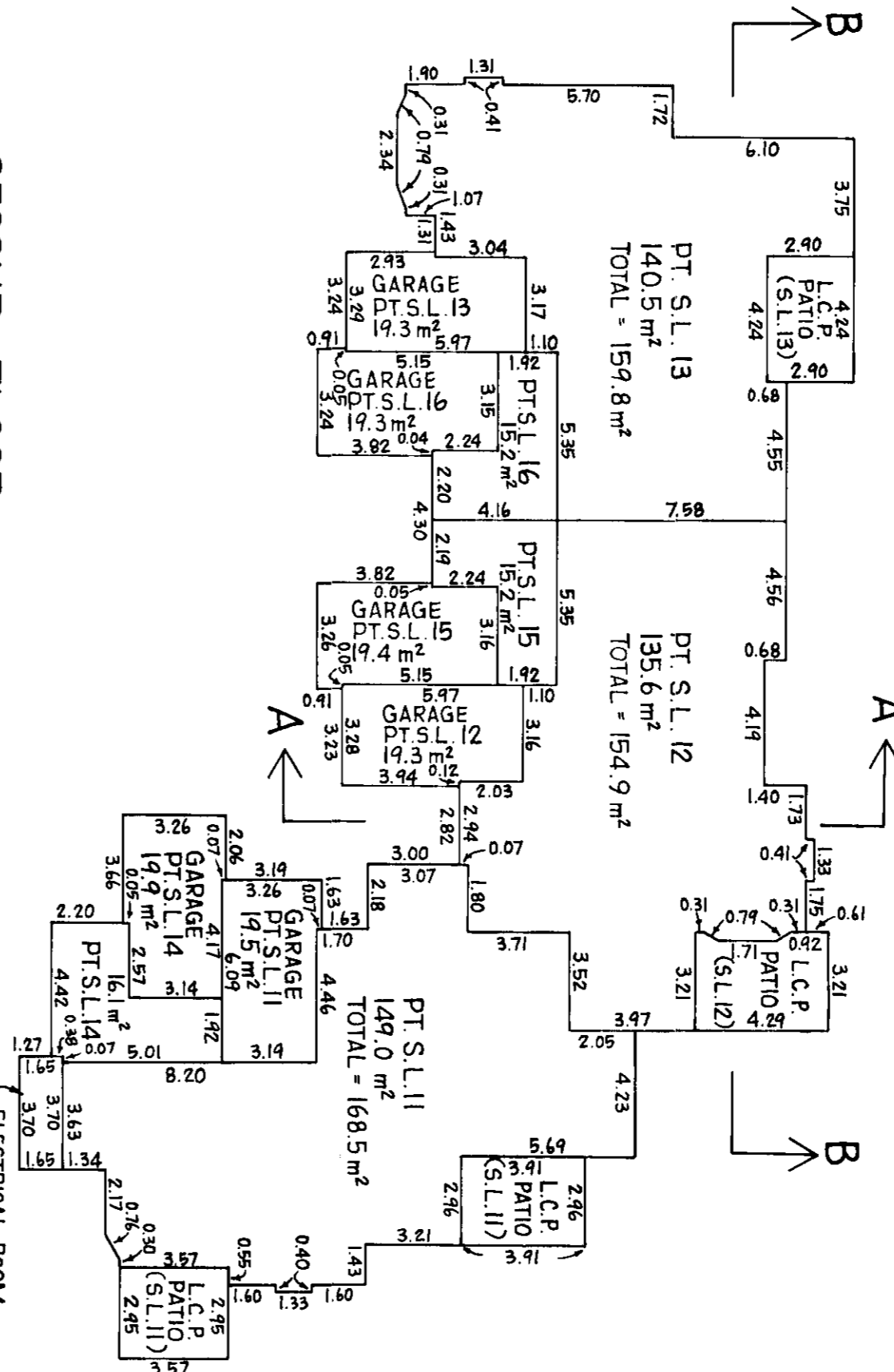

SECOND FLOOR

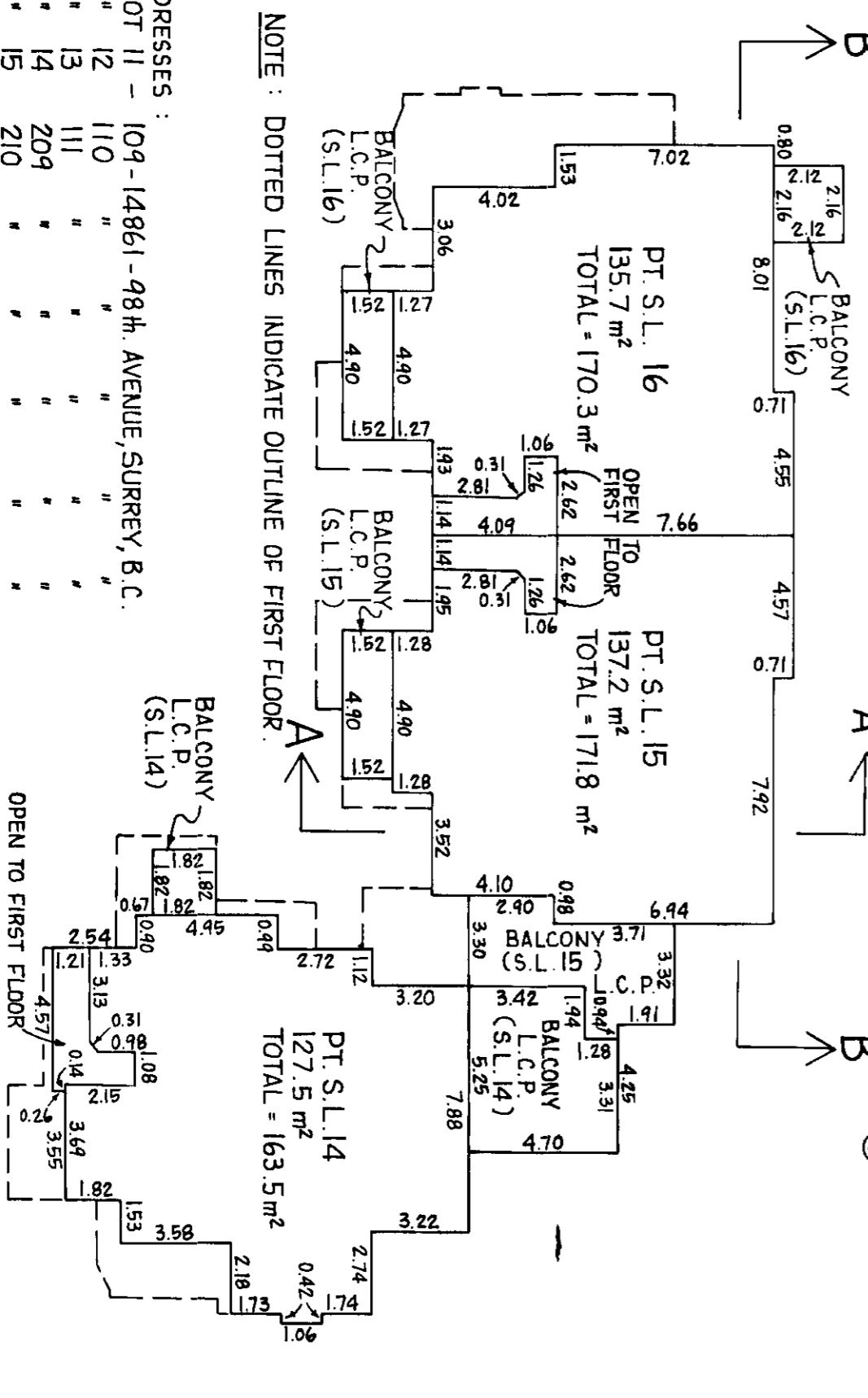

NOTE: DOTTED LINES INDICATE OUTLINE OF FIRST FLOOR.

CIVIC ADDRESSES:

STRATA LOT #	Address
109	14861-98th AVENUE, SURREY, B.C.
110	"
111	"
113	"
114	"
1209	"
210	"
211	"

9/2/88

11427

BUILDING NINE

STRATA PLAN N.W. 2754

PHASE I

SCALE - 1 : 200

LEGEND

PT.S.L. DENOTES PART STRATA LOT.
 m² " " SQUARE METRES.
 L.C.P. " " LIMITED COMMON PROPERTY.

FIRST FLOOR

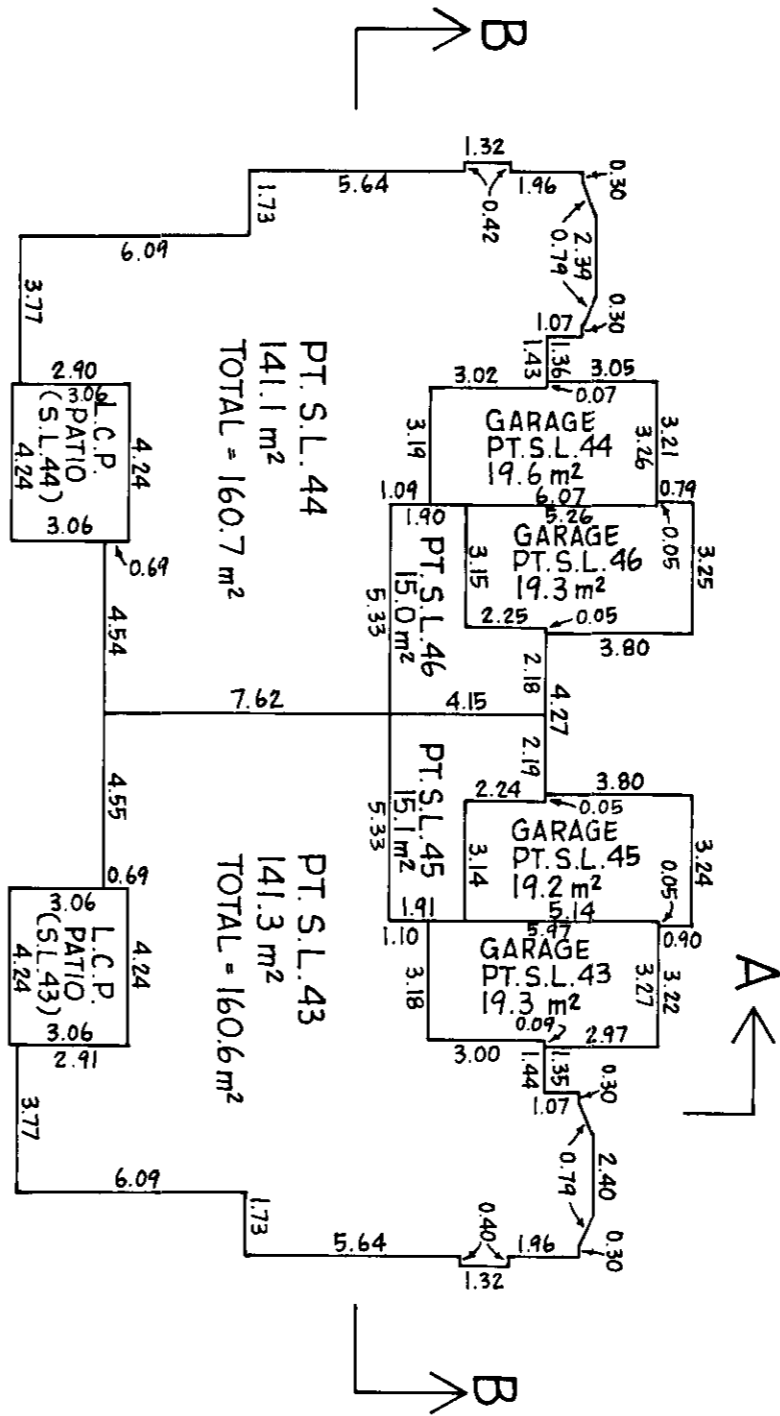

SECOND FLOOR

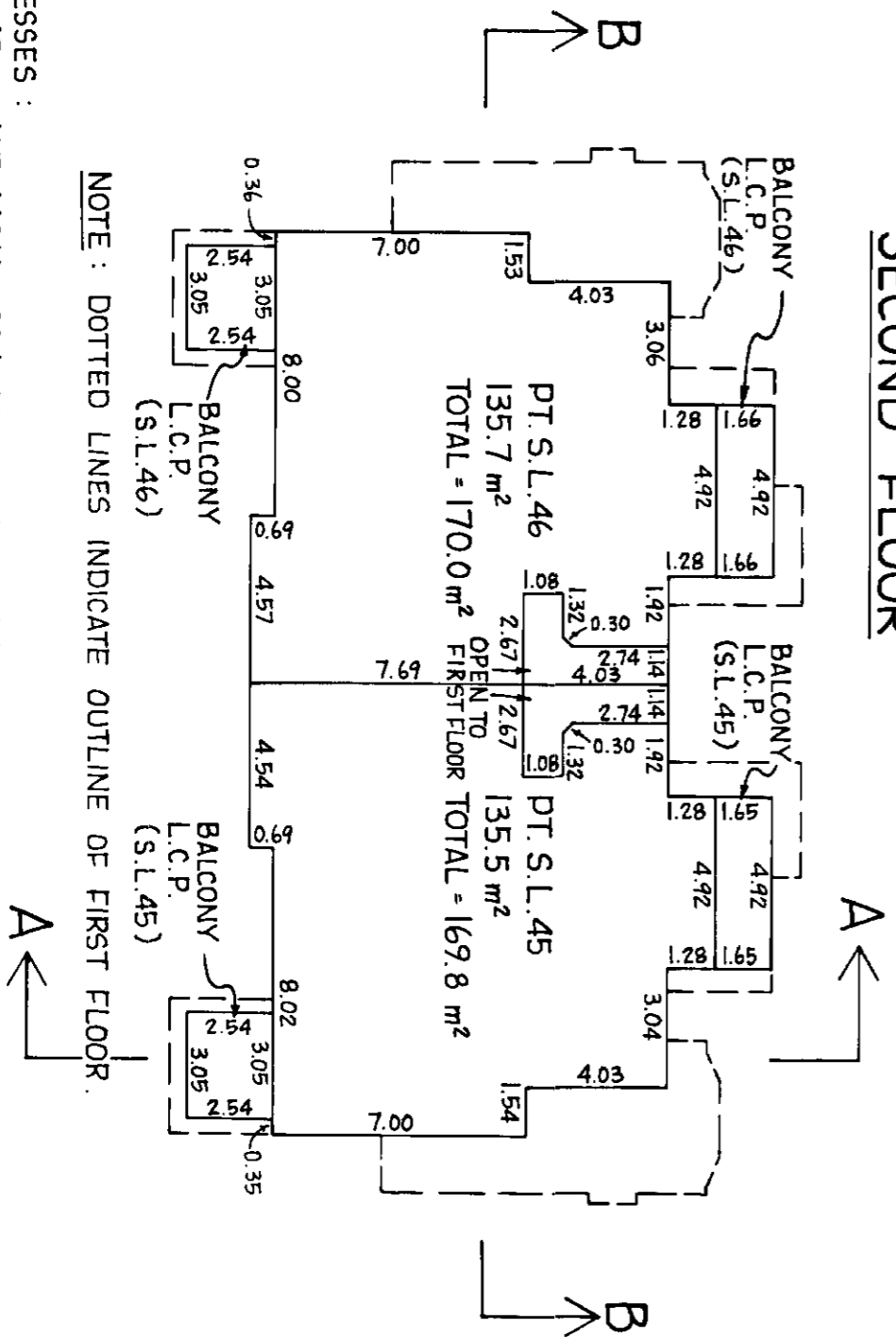

NOTE : DOTTED LINES INDICATE OUTLINE OF FIRST FLOOR.

CIVIC ADDRESSES :
 STRATA LOT 43 - 107-14861 - 98th. AVENUE, SURREY, B.C.
 " " " " " " " " " " " "
 " " " " " " " " " " " "
 " " " " " " " " " " " "
 " " " " " " " " " " " "

9/2/88

11427

STRATA PLAN NW. 2754
PHASE 1

BUILDING ONE
ELEVATION SECTIONS

SCALE - 1:200

LEGEND

⊙ DENOTES COMMON PROPERTY.
PT. S.L. DENOTES PART STRATA LOT.

SECTION A-A

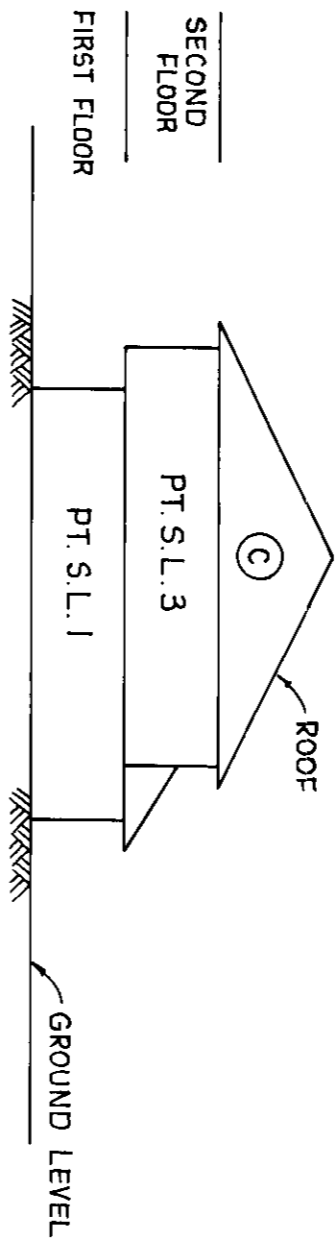

SECTION B-B

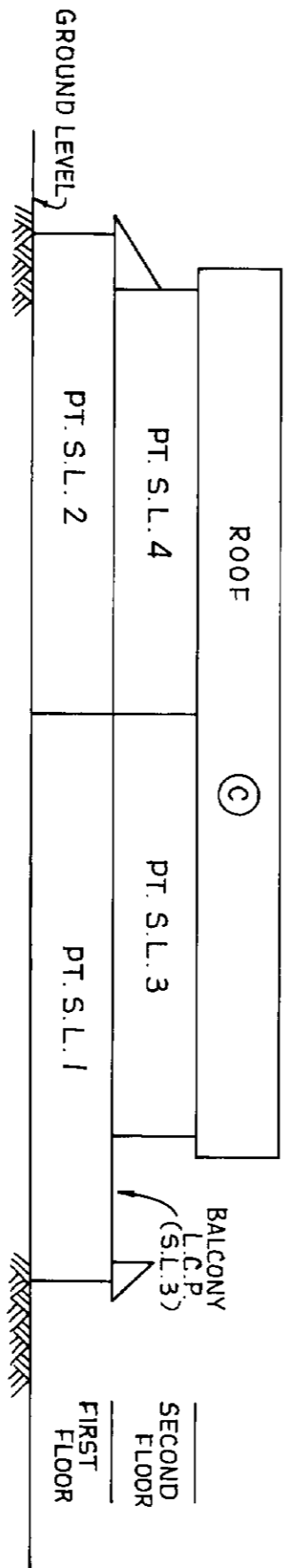

Handwritten signature
9/2/88

BUILDING TWO

ELEVATION SECTIONS

SCALE - 1:200

LEGEND

Ⓢ DENOTES COMMON PROPERTY.
PT. S.L. DENOTES PART STRATA LOT.

STRATA PLAN N.W. 2754
PHASE 1

SECTION A-A

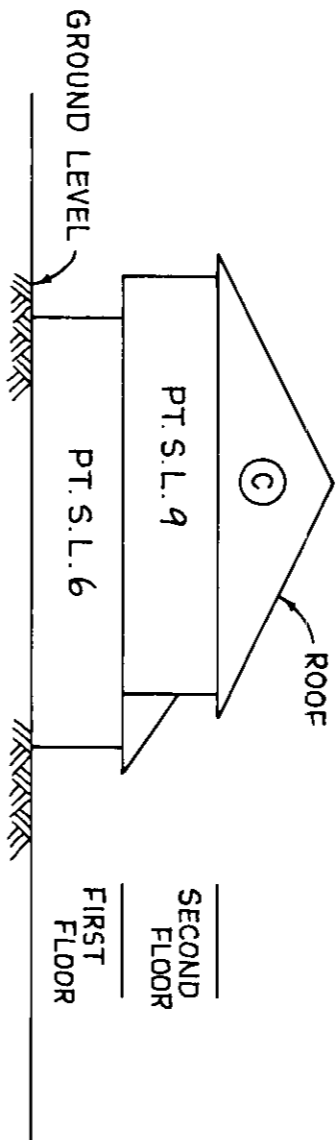

SECTION B-B

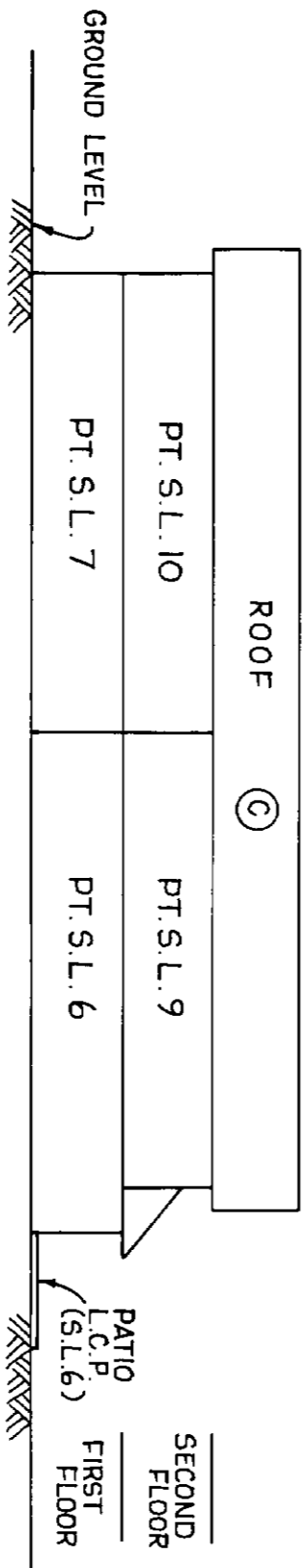

11427

duo
9/2/08

STRATA PLAN N.W. 2754
PHASE 1

BUILDING THREE
ELEVATION SECTIONS

SCALE - 1:200

LEGEND

Ⓢ DENOTES COMMON PROPERTY.
PT.S.L. DENOTES PART STRATA LOT.

SECTION A-A

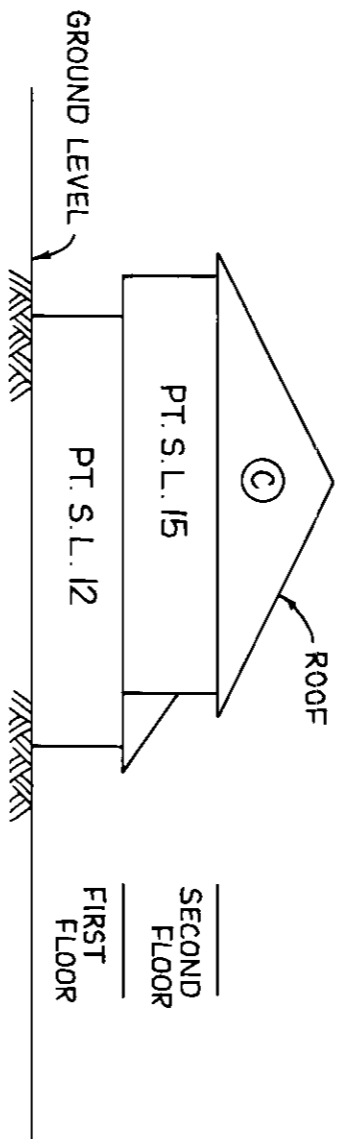

SECTION B-B

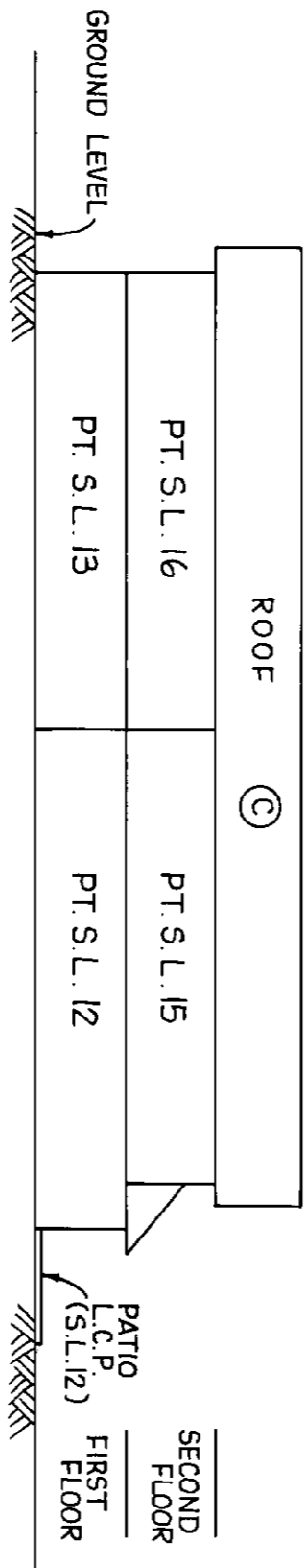

11427

Quigley
9/2/98

BUILDING NINE

ELEVATION SECTIONS

SCALE - 1:200

LEGEND

Ⓢ DENOTES COMMON PROPERTY.
PT. S.L. DENOTES PART STRATA LOT.

STRATA PLAN N.W. 2754
PHASE 1

SECTION A-A

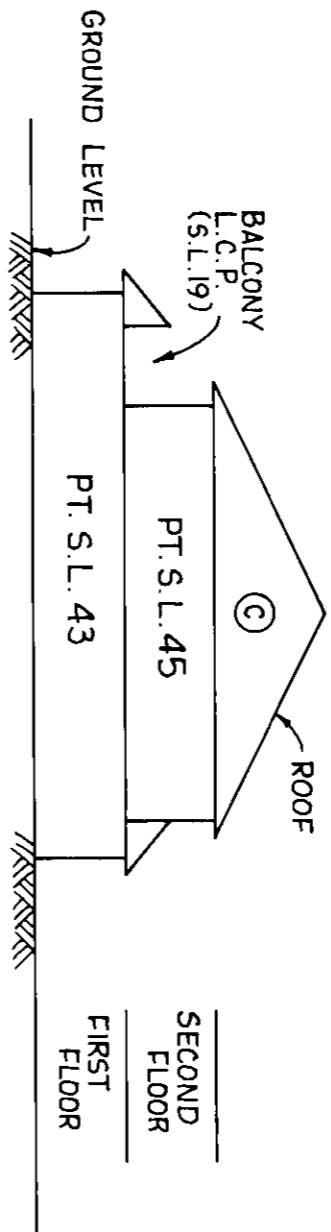

SECTION B-B

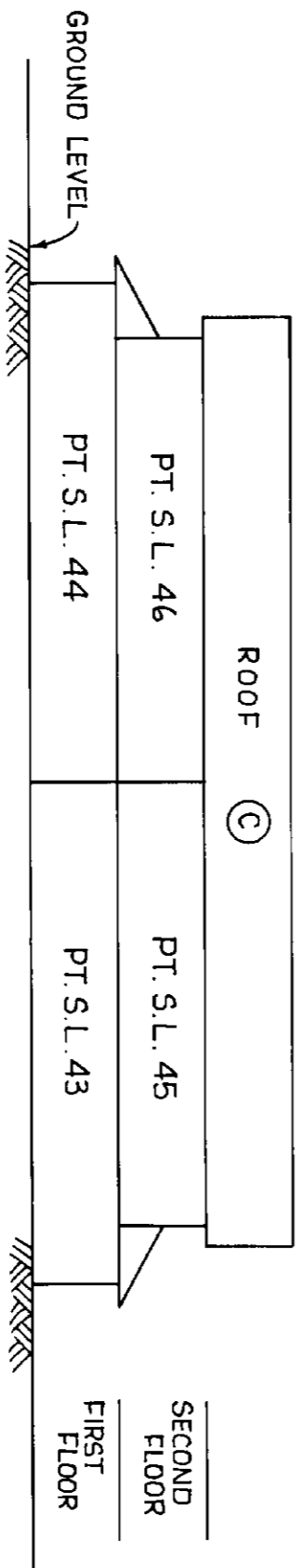

Dino
9/2/88

Common Property Sheet Closed 22/11/95

Search ATIOS2 or BC Online for Current Information BC Reg. 76/95

Boer

LINDA J. OSHEA, Registrar
Vancouver/New Westminster Land Title Districts

DEALINGS AFFECTING THE COMMON PROPERTY

SHEET 13 OF 14 SHEETS

STRATA PLAN NW 2754

PAGE ONE

REGISTRATION NUMBER	DATE	DATE	DOCUMENT NATURE AND PARTICULARS
AA68020	23.4.87	@ 14:36	EASEMENT HERE TO IS ANNEXED EASEMENT AA68020 OVER (PLAN 74361) LOT D PLAN 74360
AA107420	11.6.87	@ 9:55	PERMIT THIS TITLE MAY BE AFFEDED BY A PERMIT UNDER PART 29 OF THE MUNICIPAL ACT EXPIRES: JUNE 8, 1989
Z7969	16.1.86	@ 14:33	COVENANT DISTRICT OF SUREBY L.T.A. SEC. 215 INTERALIA
Z7970	16.1.86	@ 14:34	STATUTORY RIGHT OF WAY DISTRICT OF SUREBY NBETH 3.65 METRES INTERALIA
AA68022	23.4.87	@ 14:36	STATUTORY RIGHT OF WAY DISTRICT OF SUREBY PLAN 74362 INTER ALIA
AA68023	23.4.87	@ 14:37	COVENANT DISTRICT OF SUREBY L.T.A. SEC. 215 INTER ALIA
AA227910	27.11.87	@ 13:59	STATUTORY RIGHT OF WAY BRITISH COLUMBIA HYDRO AND POWER AUTHORITY INTER ALIA
AB204798	03-10-1988	11:43	Statutory Right of Way B.C. Gas Inc. (Incorporation No. 74280) Assignment of AA227910 Rec'd 29/11/1989 @ 13:59 Inter Alia
AC112995	08.05.1989	14:45	EASEMENT PLAN 81526 ANNEXMENT TO LOT 3 PLAN 74360
AC124721	24.05.1989	10:44	STATUTORY RIGHT OF WAY BRITISH COLUMBIA HYDRO AND POWER AUTHORITY
AC135344	08.06.1989	13:45	STATUTORY RIGHT OF WAY BRITISH COLUMBIA TELEPHONE COMPANY
			CONT'D P4/139

11427

Boer
9/12/88

PHASED STRATA PLAN OF LOT 'C' OF SECTION 32,
BLOCK 5 NORTH, RANGE 1 WEST,
PLAN 74360, NEW WESTMINSTER DISTRICT
INTEGRATED SURVEY AREA N^o 1
MUNICIPALITY OF SURREY, B.C.

STRATA PLAN N.W. 2754
PHASE 2 *Rev. Ac 6505 Ac 6532*

DEPOSITED AND REGISTERED
IN THE LAND TITLE OFFICE
AT NEW WESTMINSTER, B.C.
THIS 20 DAY OF *Jan* 1989

E.J. Raven
REGISTRAR

SCALE - 1:1000

ALL DISTANCES ARE IN METRES.
LEGEND GRID BEARINGS ARE DERIVED FROM PLAN 74360.
THIS PLAN SHOWS GROUND-LEVEL MEASURED DISTANCES.
PRIOR TO COMPUTATION OF UTM CO-ORDINATES, MULTIPLY
BY COMBINED FACTOR 0.9995970.

Ⓢ DENOTES COMMON PROPERTY.
THE ADDRESS FOR SERVICE OF DOCUMENTS ON THE STRATA CORPORATION
IS : THE OWNERS, STRATA PLAN N.W. 2754, 101-14861-98th. AVE., SURREY, B.C.
CIVIC ADDRESSES ARE SHOWN ON SHEETS 7, 8, 9, 10 AND 11

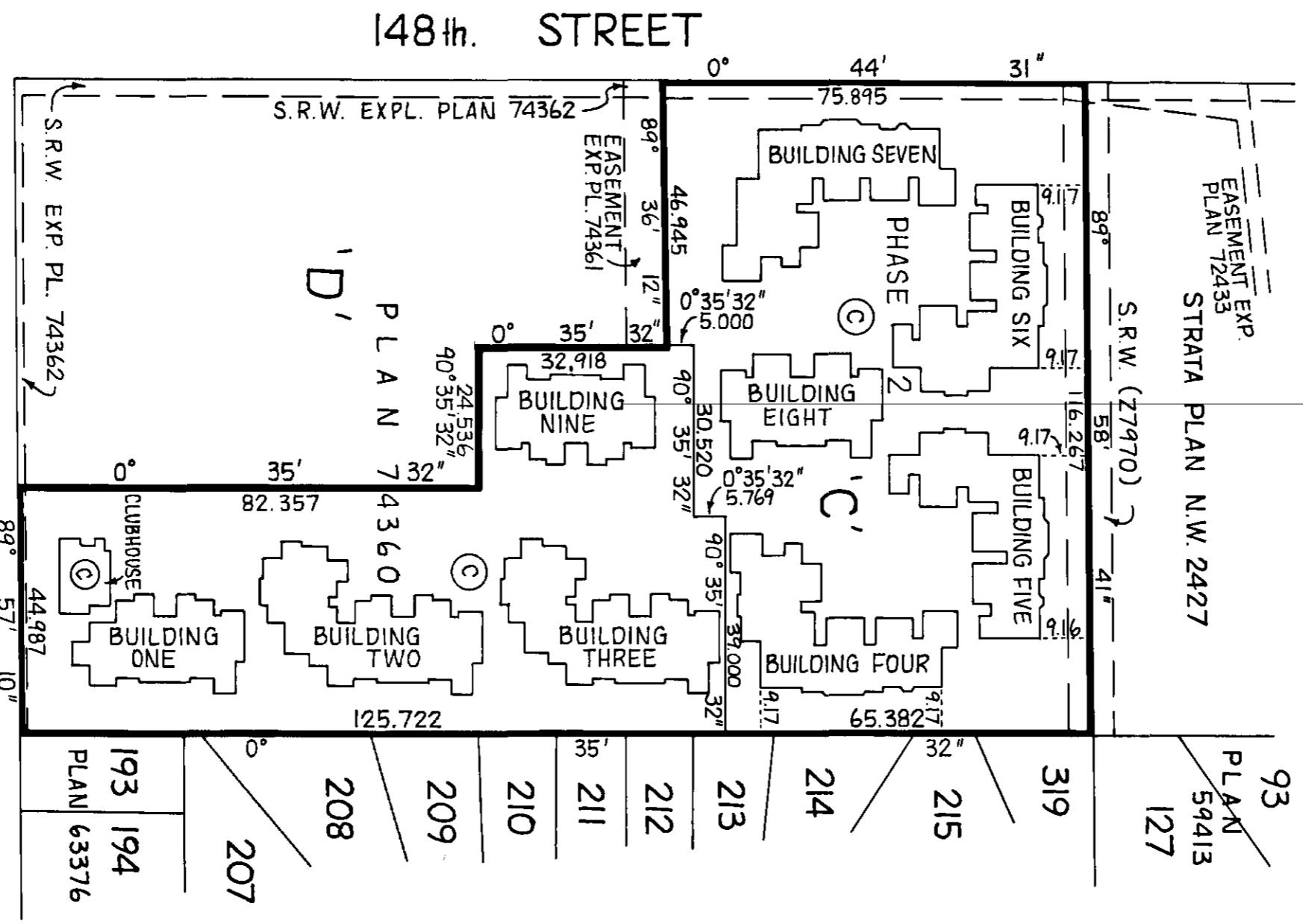

APPROVED AS TO PHASE 2 OF A
TWO PHASE STRATA PLAN UNDER
THE CONDOMINIUM ACT.
DATED THIS 9th DAY OF *January*, 1989.

See Sign.
APPROVING OFFICER - MUNICIPALITY OF SURREY

ISAAC, OSMAN & ASSOCIATES
B.C. LAND SURVEYORS
20609 LOGAN AVENUE
LANGLEY, B.C. V3A 7R3
phone 533-2411

I.A.M. OSMAN, A BRITISH COLUMBIA LAND SURVEYOR,
OF LANGLEY, B.C. HEREBY CERTIFY THAT THE
5 BUILDINGS ERCTED ON THE PARCEL DESCRIBED
ABOVE ARE WHOLLY WITHIN THE BOUNDARIES
OF THAT PARCEL.

[Signature]
B.C.L.S.
DATED AT LANGLEY B.C. THIS 2nd DAY OF DECEMBER, 1988

FILE 11427-2 (NU PACIFIC REALTY DEV. LTD.)

THIS PLAN LIES WITHIN THE
GREATER VANCOUVER REGIONAL DISTRICT

FOUNDATION PERIMETER OF BUILDINGS FOUR AND EIGHT

STRATA PLAN N.W. 2754 PHASE 2

SCALE - 1 : 200



ALL DISTANCES ARE IN METRES.

LEGEND
⊙ DENOTES COMMON PROPERTY.

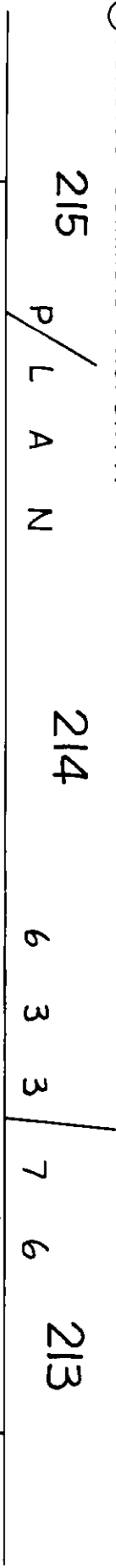

⊙

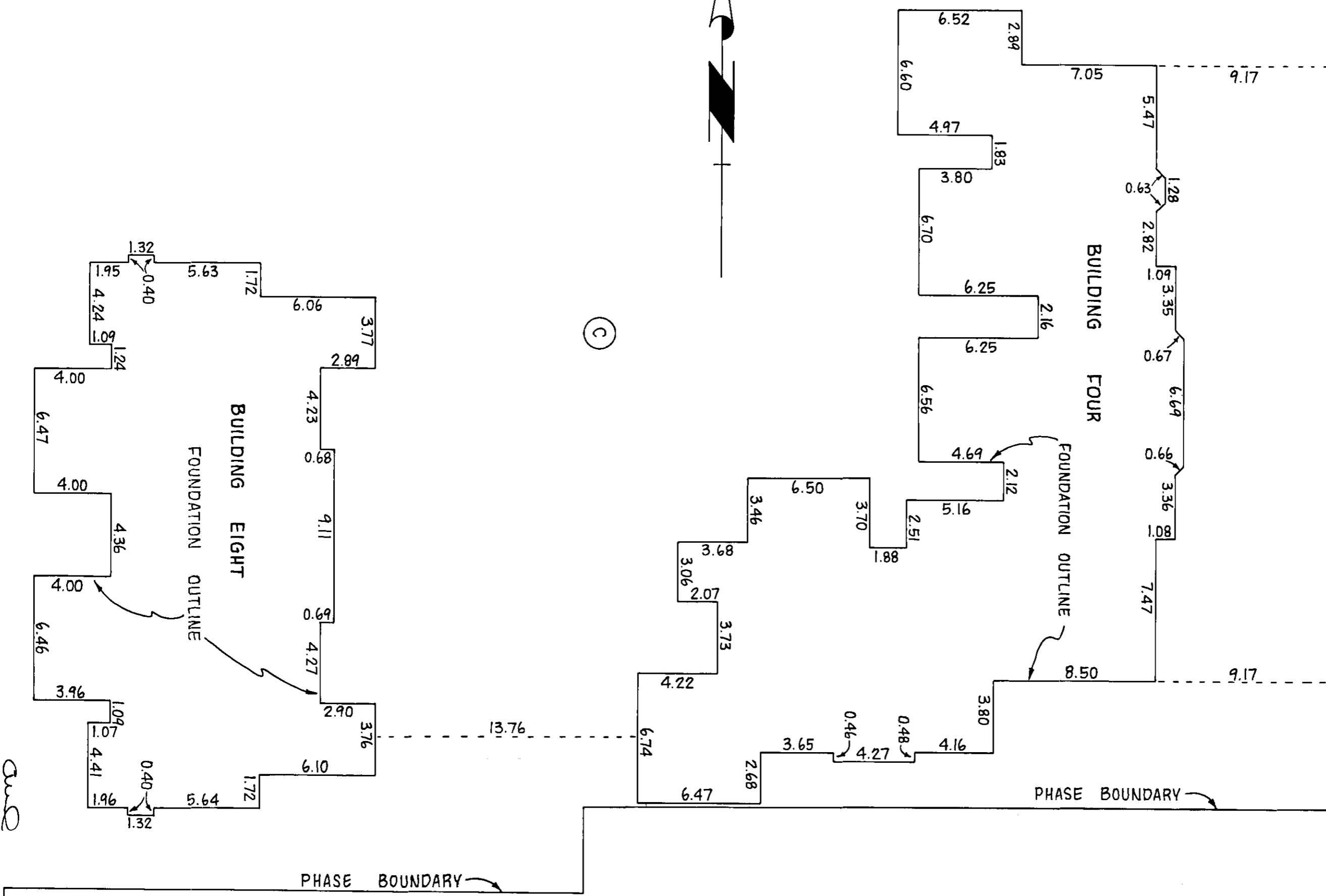

Handwritten signature and date: 5/12/83

11427-2

FOUNDATION PERIMETER OF BUILDING FIVE

STRATA PLAN N.W. 2754 PHASE 2

SCALE - 1:200 

ALL DISTANCES ARE IN METRES.

LEGEND

Ⓢ DENOTES COMMON PROPERTY.

STRATA PLAN N.W. 2427

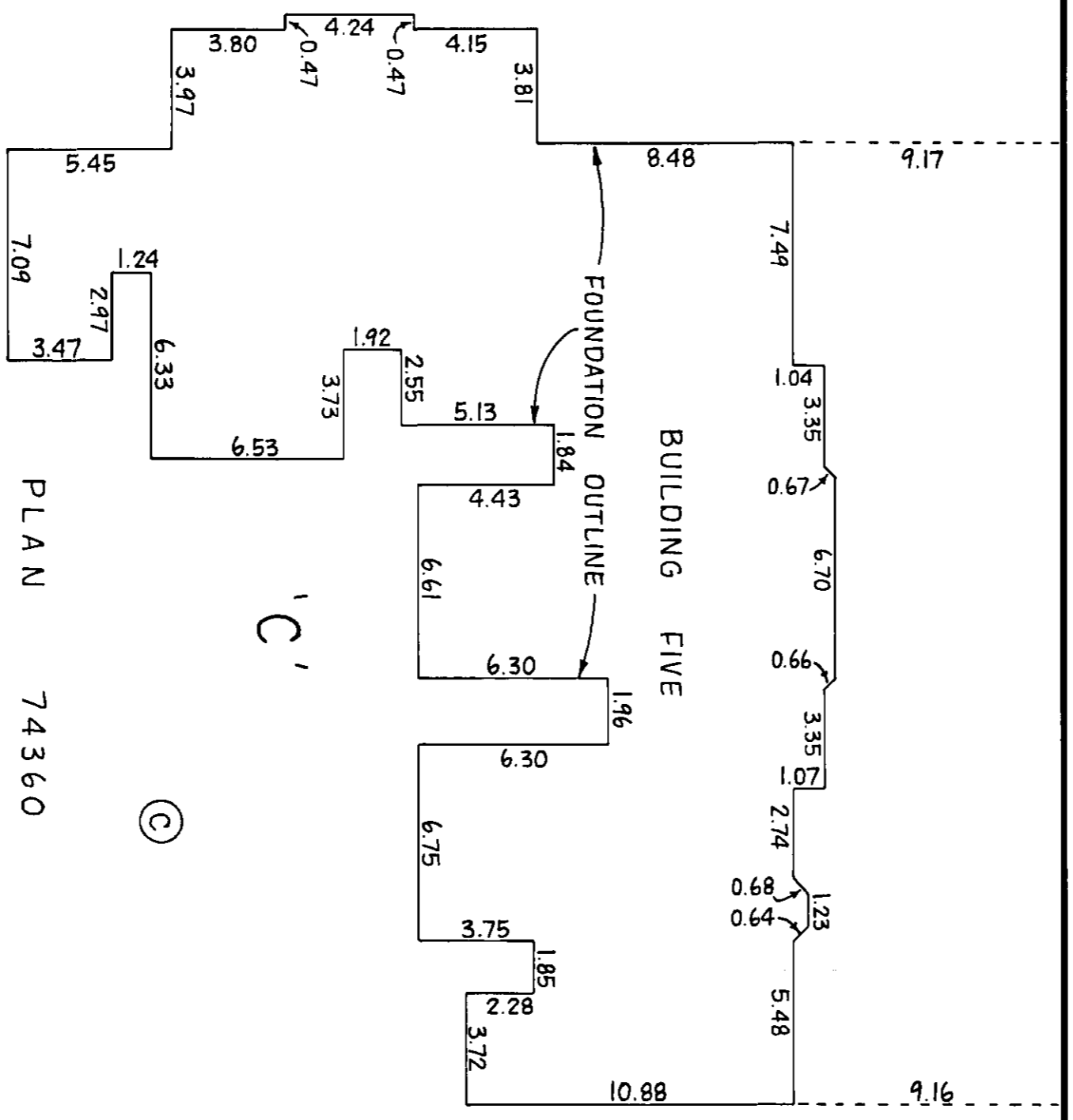

PLAN 74360

11427-2

Handwritten signature
5/12/98

FOUNDATION PERIMETER OF BUILDING SIX

STRATA PLAN N.W. 2754 PHASE 2

SCALE - 1:200



ALL DISTANCES ARE IN METRES.

LEGEND

Ⓢ DENOTES COMMON PROPERTY.

STRATA PLAN N.W. 2427

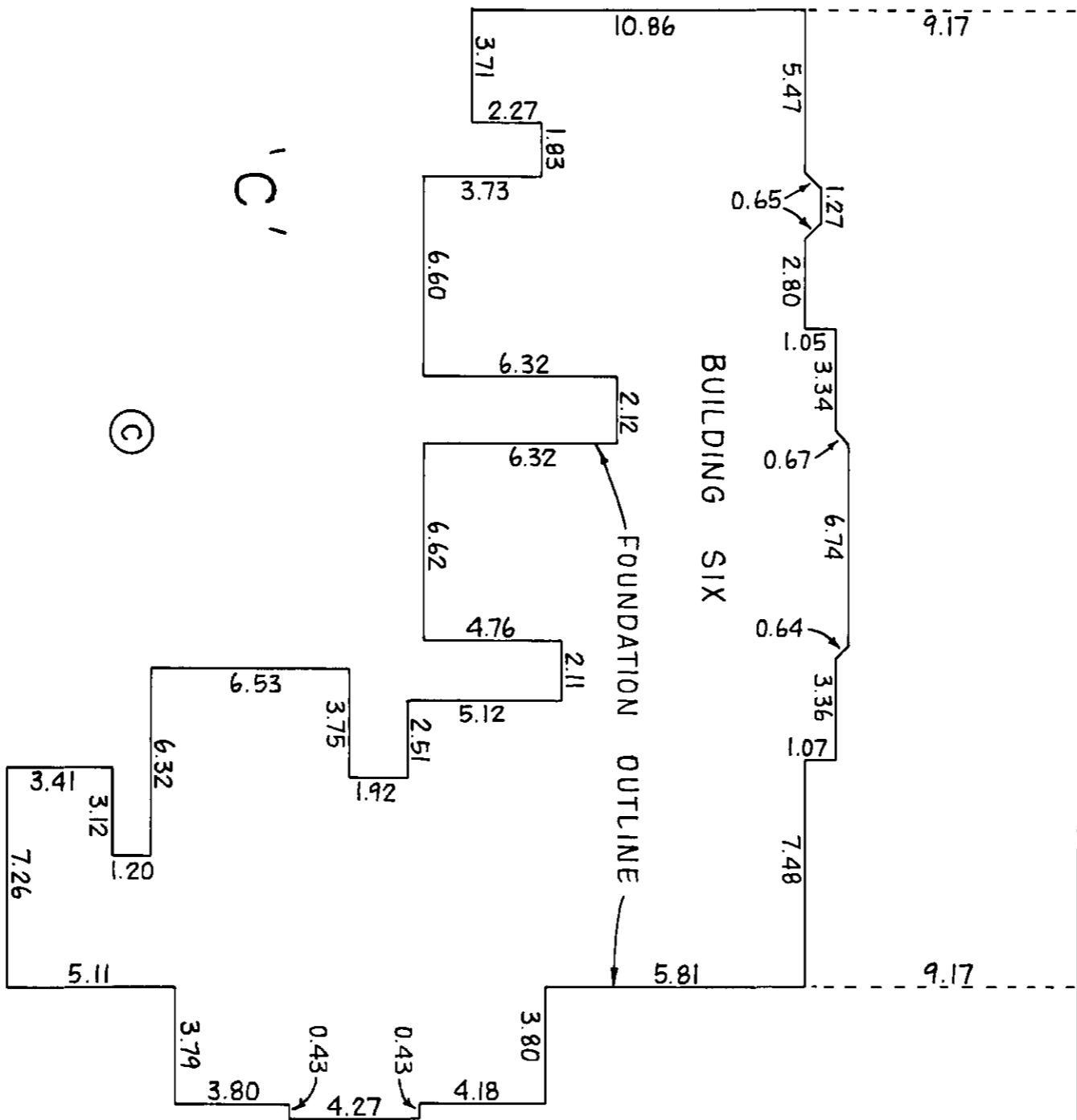

PLAN 74360

11427-2

Aug
5/12/03

FIRST SHEET, 5 OF 16 SHEETS
STRATA PLAN N.W. 2154
PHASE 2

FOUNDATION PERIMETER OF BUILDING SEVEN

SCALE - 1 : 200
5 4 3 2 1 0 5 10

ALL DISTANCES ARE IN METRES.

LEGEND

Ⓢ DENOTES COMMON PROPERTY.

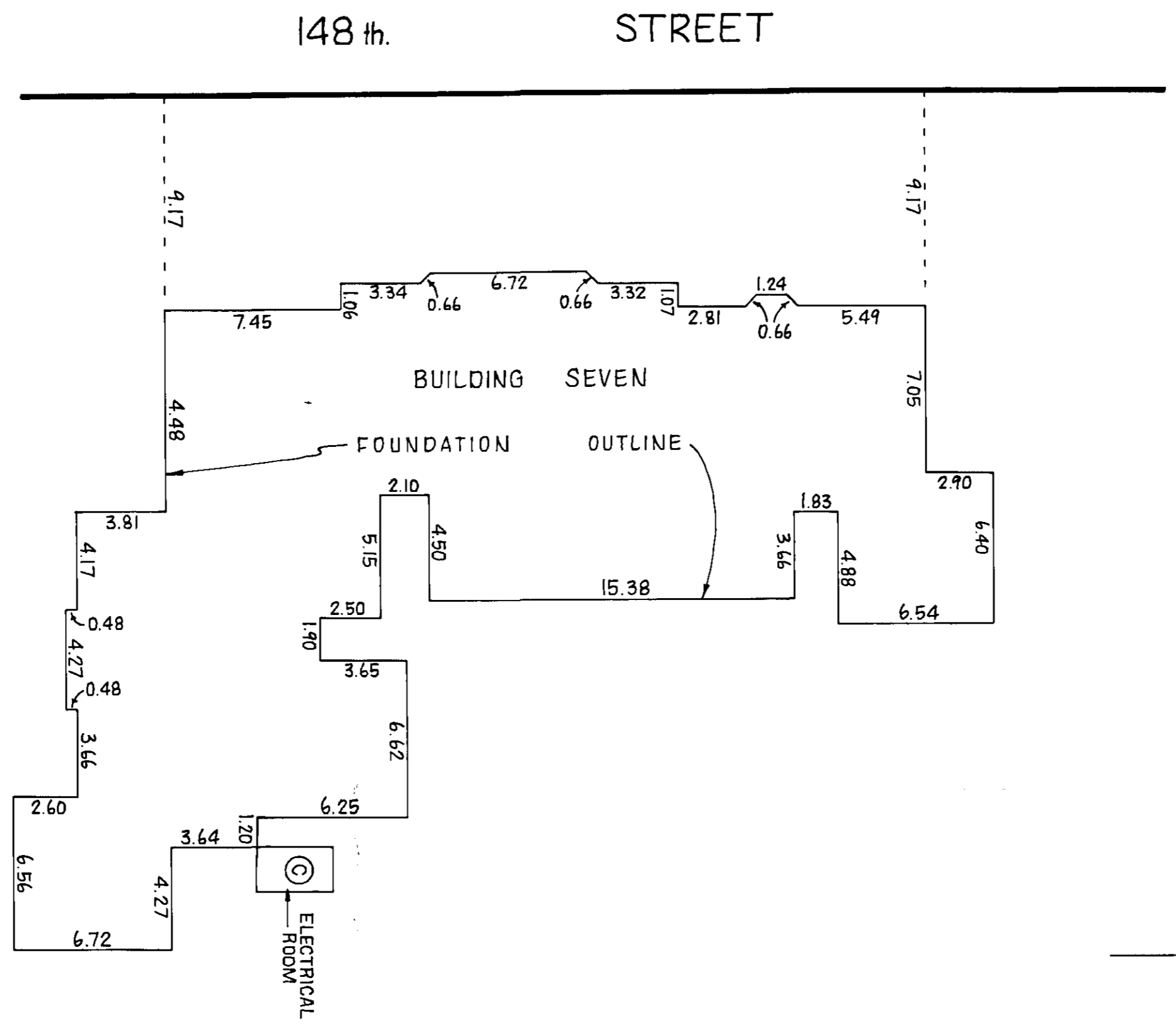

11427-2

Handwritten signature and date: 5/1/11

STRATA PLAN N.W. 2154
PHASE 2

STRATA LOT No	SHEET No	UNIT ENTITLEMENT	FORM 1 SCHEDULE OF UNIT ENTITLEMENT	FORM 2 SCHEDULE OF INTEREST UPON DESTRUCTION	FORM 3 SCHEDULE OF VOTING RIGHTS
17	7	129	130		
18	"	125	114		
19	"	124	130		
20	"	136	134		
21	"	139	127		
22	"	143	134		
23	8	138	137		
24	"	127	119		
25	"	132	124		
26	"	144	137		
27	"	139	127		
28	"	137	133		
29	9	129	124		
30	"	127	119		
31	"	138	137		
32	"	136	134		
33	"	140	127		
34	"	144	134		
35	10	124	130		
36	"	126	119		
37	"	131	128		
38	"	145	137		
39	"	139	137		
40	"	139	137		
41	11	143	139		
42	"	143	139		
47	"	139	125		
48	"	139	133		
AGGREGATE		3795	3645		

NOTE: UNIT ENTITLEMENT IS BASED ON HABITABLE AREA. INTEREST UPON DESTRUCTION IS BASED ON BUILDING VALUE.

NOT ACCEPTED AS TO FORMS 1 & 2 AND 3. THIS 29 DAY OF December 1988

SUPERINTENDENT OF REAL ESTATE STATUTORY DECLARATION

1, THE UNDERSIGNED DO SOLEMNLY DECLARE THAT:
1.1) THE UNDERSIGNED, AM THE DUTY AUTHORIZED AGENT OF THE OWNER - DEVELOPER.
2) THE STRATA PLAN IS ENTIRELY FOR RESIDENTIAL USE.
I MAKE THIS SOLEMN DECLARATION CONSCIENTIOUSLY BELIEVING IT TO BE TRUE AND KNOWING IT IS OF THE SAME FORCE AND EFFECT AS IF MADE UNDER OATH.

AUTHORIZED SIGNATORY FOR THE AGENT OF THE OWNER - DEVELOPER

A COMMISSIONER FOR TAKING AFFIDAVITS WITHIN BRITISH COLUMBIA

SIGNED, SEALED AND DELIVERED IN THE PRESENCE OF:
300 - 875 West Georgia St. Vancouver, B.C.
16th Floor 555 Burrard St, Vancouver B.C. V7X 1K1

HONG KONG BANK OF CANADA
HONG KONG BANK OF CANADA
BY ITS LAWFUL ATTORNEYS
T.T. McCOLL, CREDIT SENIOR MANAGER, CREDIT
R.S. ANTROWY, ASSISTANT VICE-PRESIDENT, CREDIT

OWNER:
NU PACIFIC REALTY DEVELOPMENT (GUILDFORD) LTD. (INC. # 325818)

NELS GEORGE HAGENSON

MIDLAND DOHERTY LIMITED (REGISTRATION NO 11330A)

GUARANTEE TRUST COMPANY OF CANADA (REGISTRATION NO 577)

1501 - 736 Granville St, Vancouver

I, A.M. OSMAN, A BRITISH COLUMBIA LAND SURVEYOR, HEREBY CERTIFY THAT THE FIVE BUILDINGS SHOWN IN THIS STRATA PLAN HAVE NOT AS OF THE 5th DAY OF DECEMBER, 1988 BEEN PREVIOUSLY OCCUPIED. DATED AT LANGLEY, BRITISH COLUMBIA, THIS 5th DAY OF DECEMBER, 1988.

BUILDING FOUR

**STRATA PLAN N.W. 2754
PHASE 2**

SCALE - 1 : 200



ALL DISTANCES ARE IN METRES.

LEGEND

PT. S.L. DENOTES PART STRATA LOT.
 m² SQUARE METRES.
 L.C.P. LIMITED COMMON PROPERTY.
 © COMMON PROPERTY.



FIRST FLOOR

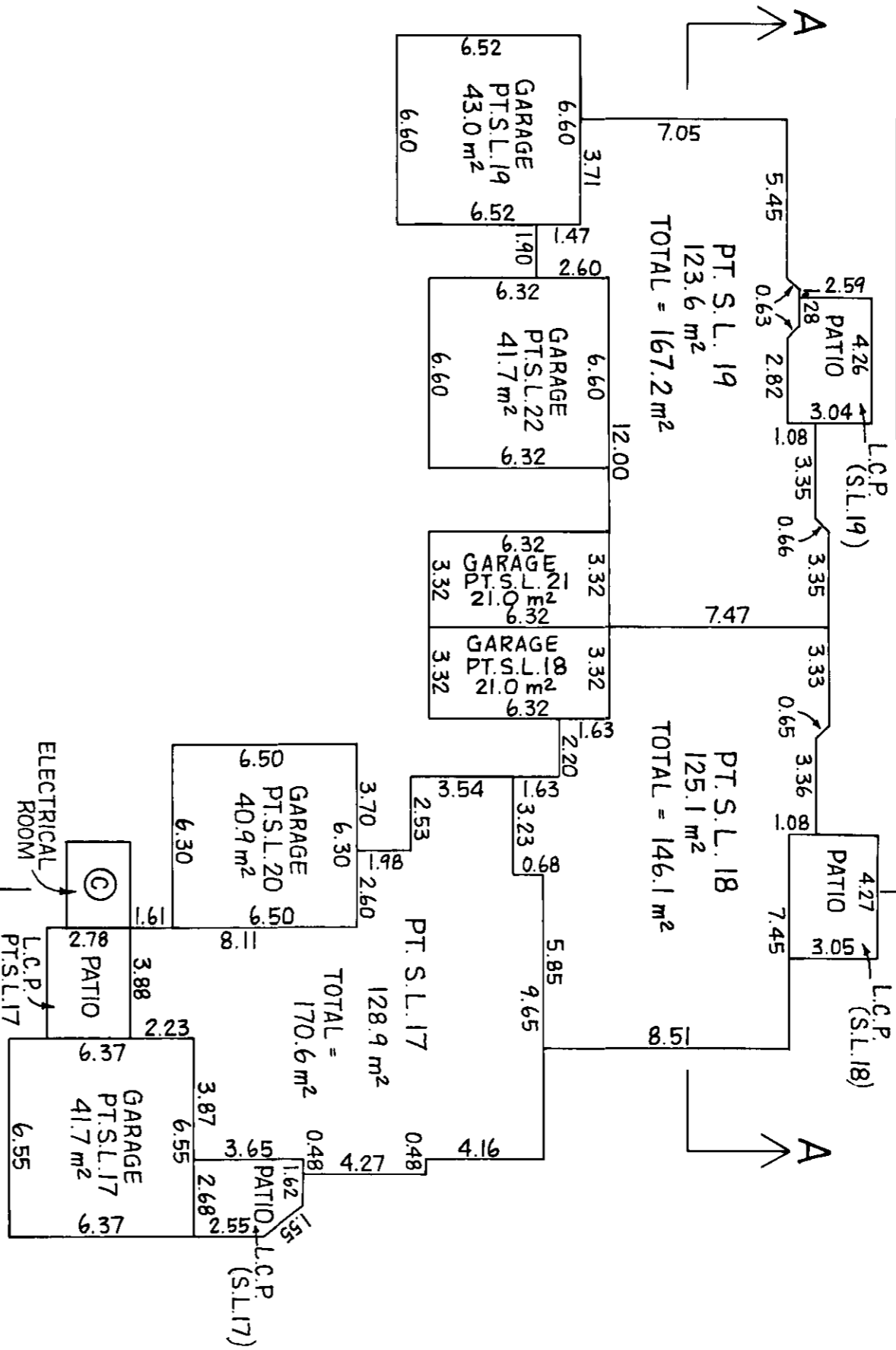

SECOND FLOOR

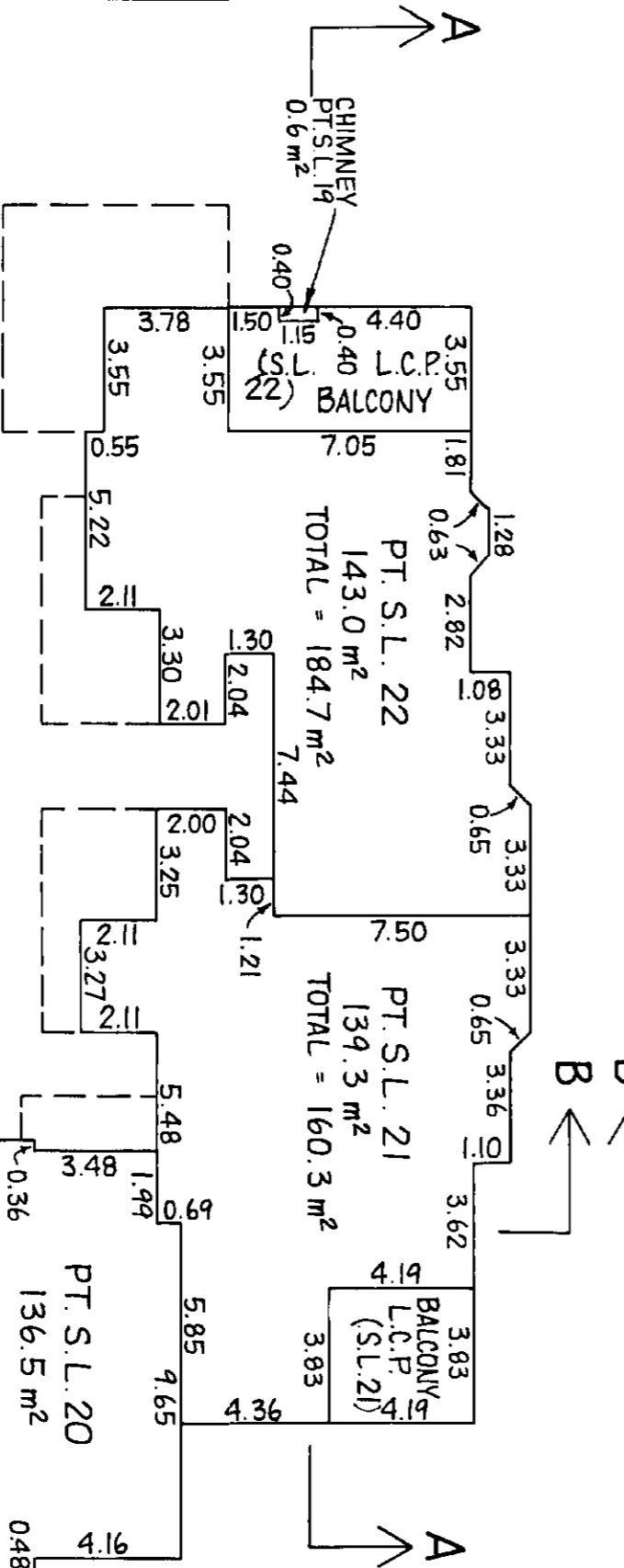

NOTE : DOTTED LINES INDICATE OUTLINE OF FIRST FLOOR.

CIVIC ADDRESSES :

STRATA LOT 17 :	112 - 14861 - 98th. AVENUE, SURREY, B.C.
" 18 :	114 " " " " " "
" 19 :	115 " " " " " "
" 20 :	212 " " " " " "
" 21 :	214 " " " " " "
" 22 :	215 " " " " " "

11427-2

5/1/1999

BUILDING FIVE

STRATA PLAN N.W. 2754 PHASE 2

SCALE - 1 : 200

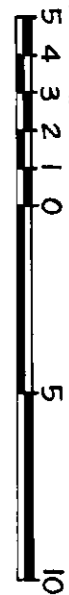

ALL DISTANCES ARE IN METRES.

LEGEND
 PT.S.L. DENOTES PART STRATA LOT.
 m² SQUARE METRES.
 L.C.P. " LIMITED COMMON PROPERTY.

FIRST FLOOR

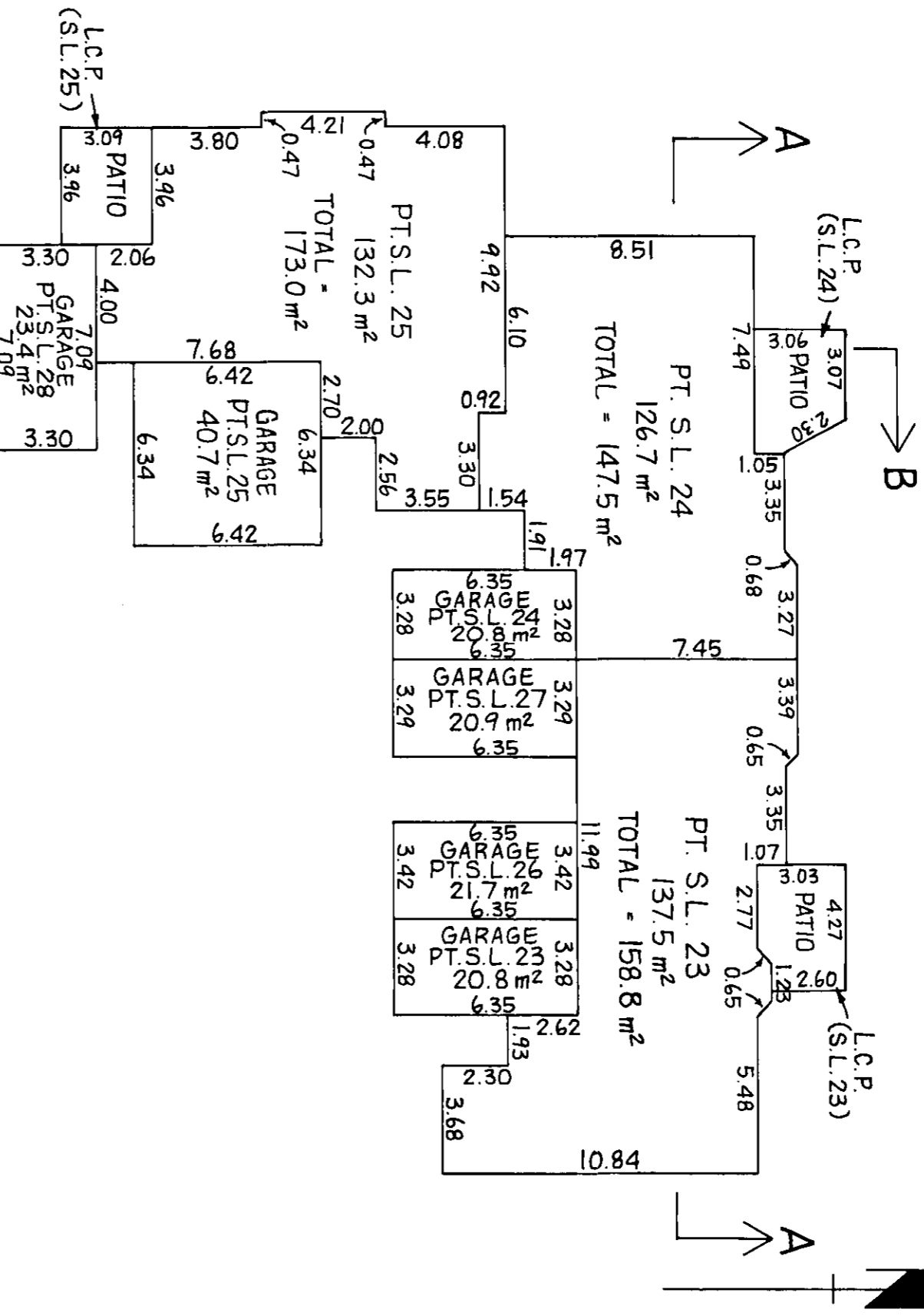

SECOND FLOOR

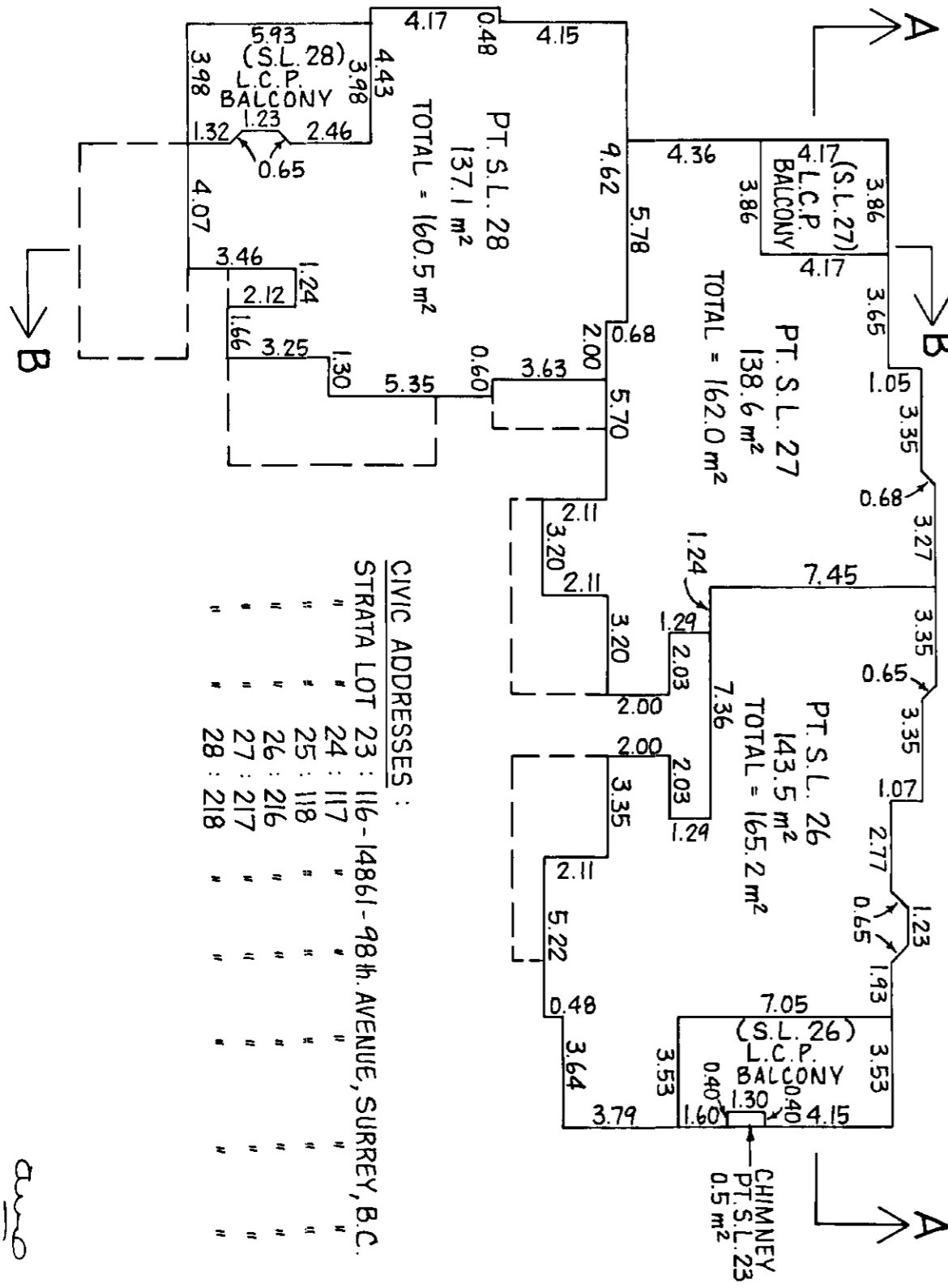

CIVIC ADDRESSES :

STRATA LOT	23	24	25	26	27	28
ADDRESS	116-14861-98th AVENUE, SURREY, B.C.	117	118	216	217	218

Signature
5/12/88

11427-2

BUILDING SIX

STRATA PLAN N.W. 2754 PHASE 2

SCALE - 1:200
ALL DISTANCES ARE IN METRES.



LEGEND

PT.S.L. DENOTES PART STRATA LOT.
m² SQUARE METRES.
L.C.P. " LIMITED COMMON PROPERTY.

FIRST FLOOR

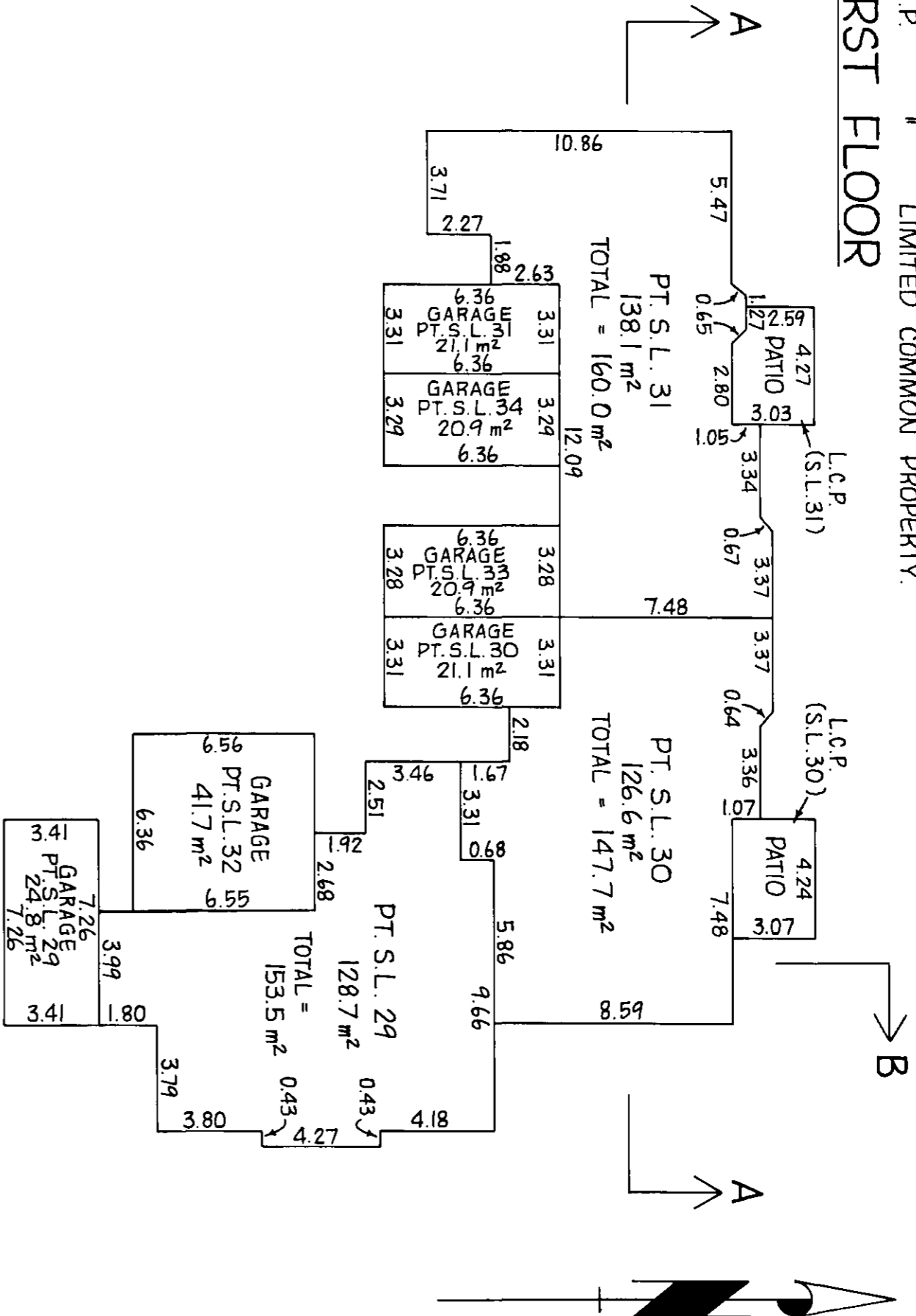

SECOND FLOOR

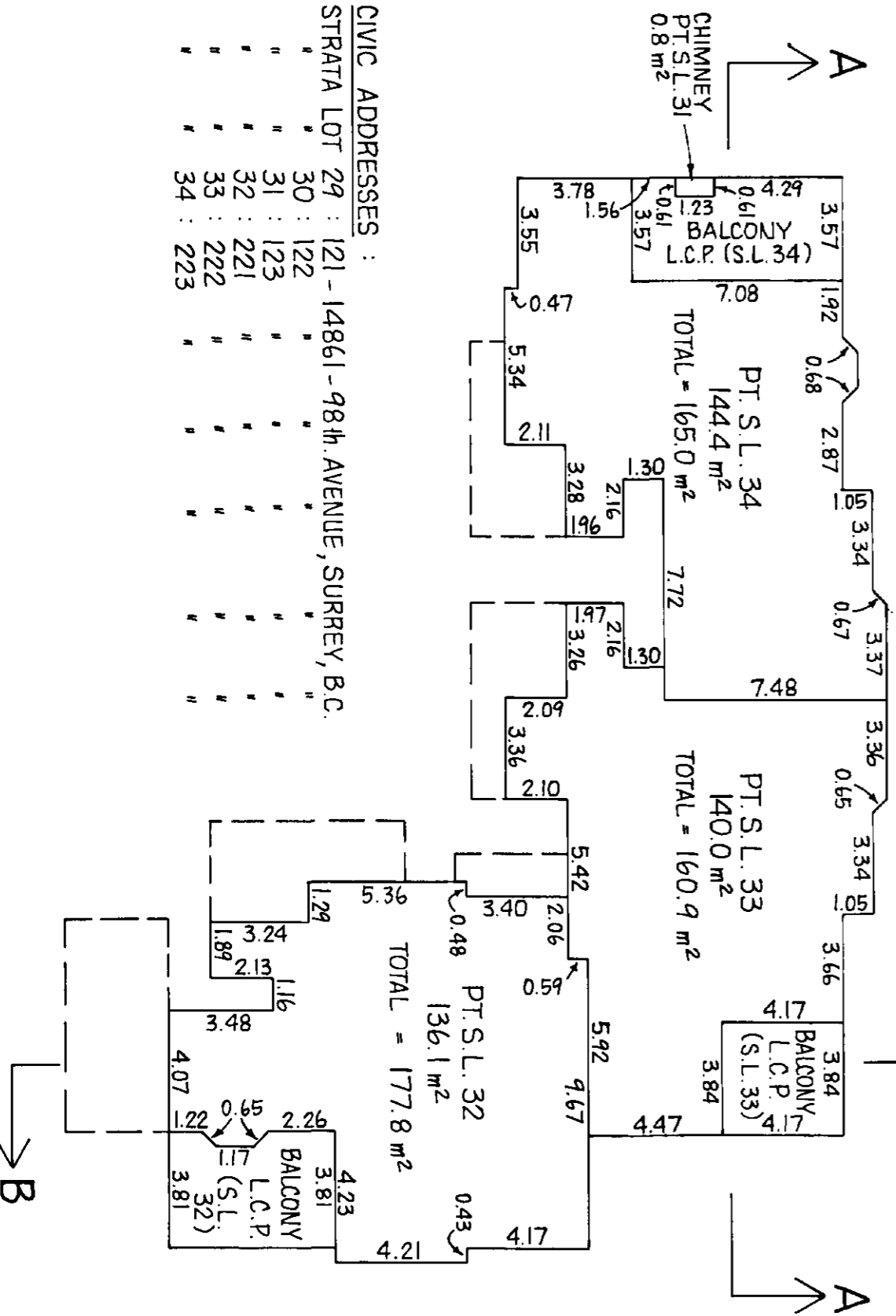

CIVIC ADDRESSES :

STRATA LOT 29 :	121 - 14861 - 98th AVENUE, SURREY, B.C.
" 30 :	122 " " " " " " " " " " " "
" 31 :	123 " " " " " " " " " " " "
" 32 :	221 " " " " " " " " " " " "
" 33 :	222 " " " " " " " " " " " "
" 34 :	223 " " " " " " " " " " " "

11427-2

Signature
5/12/88

BUILDING SEVEN

STRATA PLAN N.W. 2754 PHASE 2

SCALE - 1 : 200



ALL DISTANCES ARE IN METRES.

LEGEND

- PT.S.L. DENOTES PART STRATA LOT.
- m² " " SQUARE METRES.
- L.C.P. " " LIMITED COMMON PROPERTY.

FIRST FLOOR

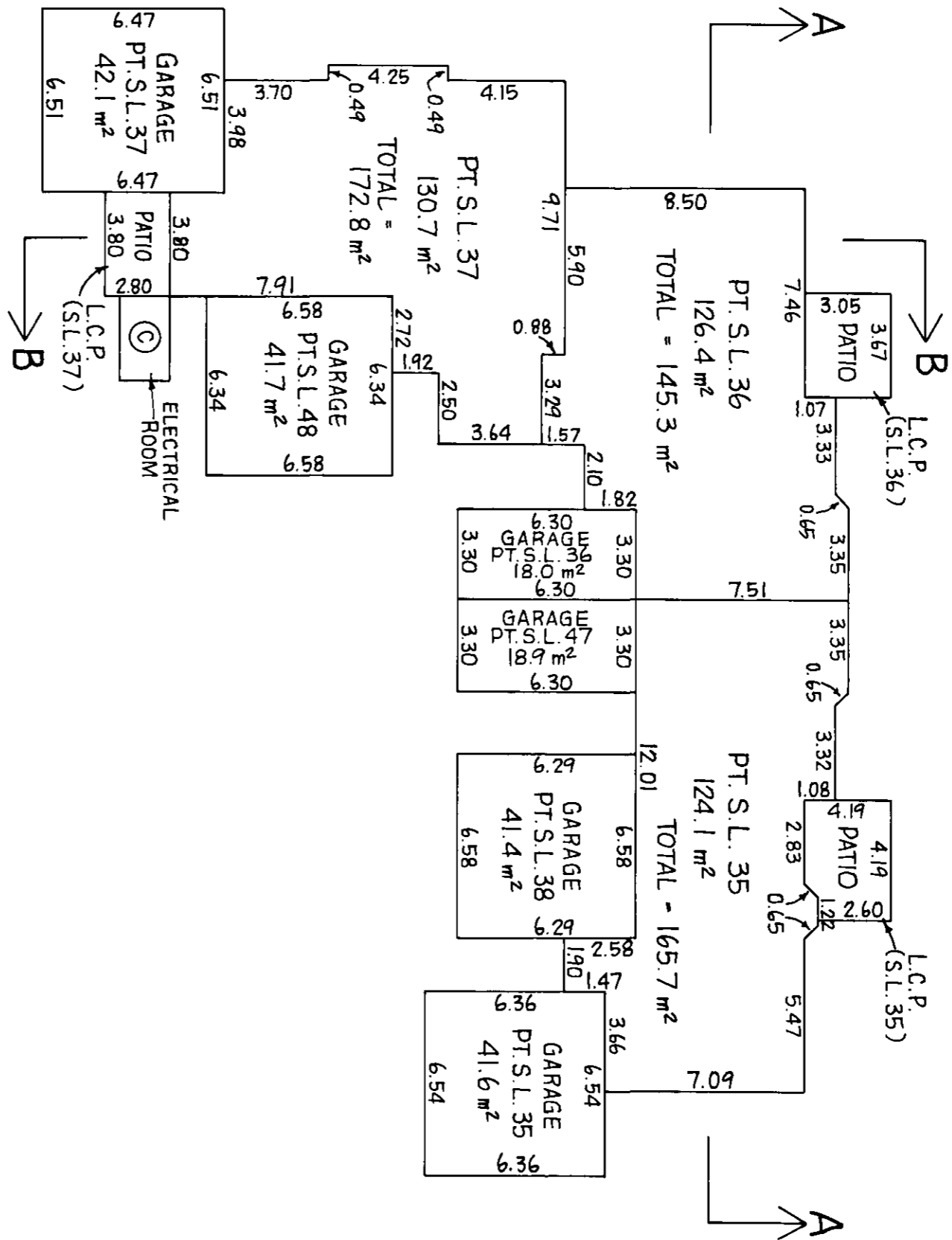

SECOND FLOOR

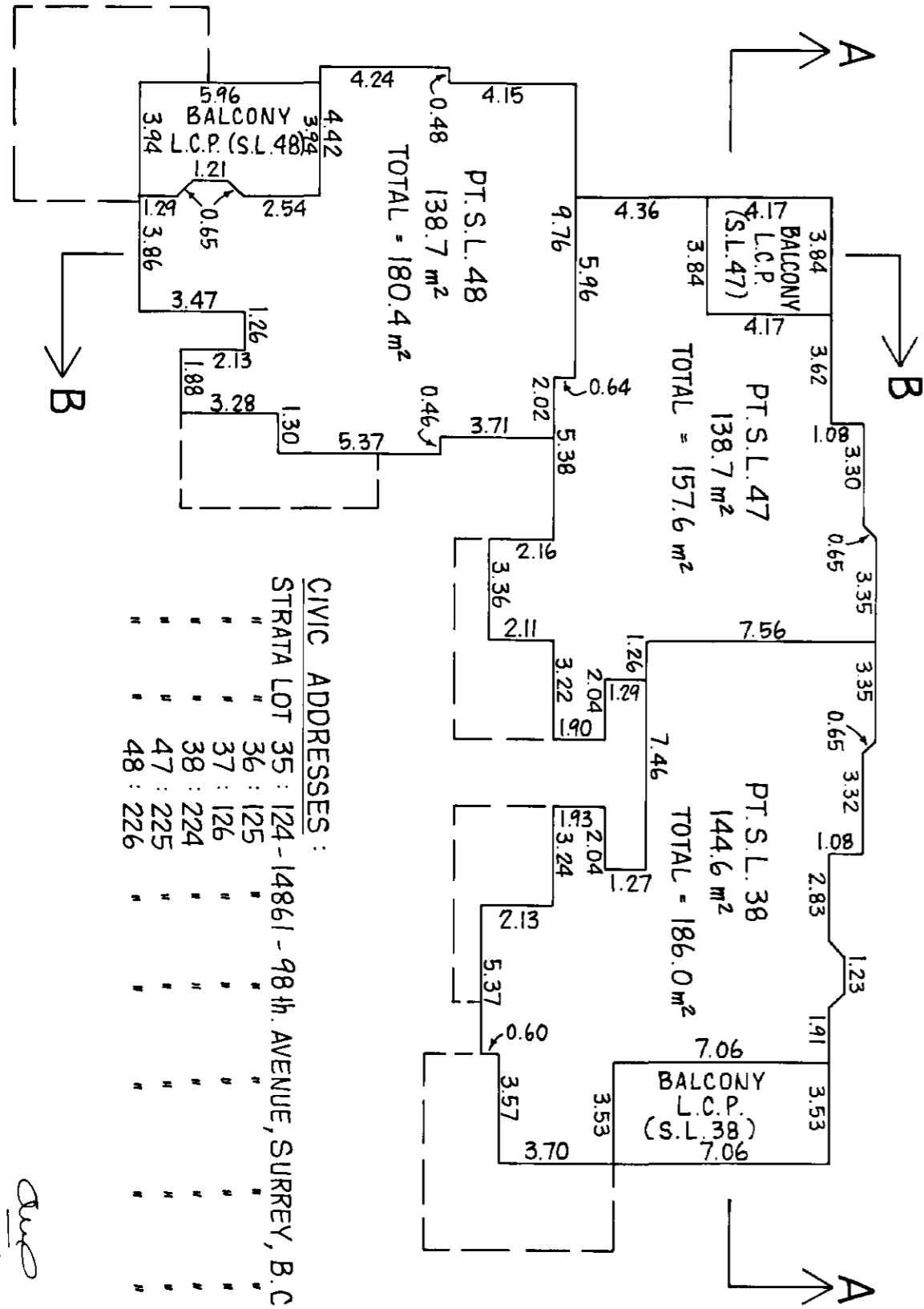

CIVIC ADDRESSES :

STRATA LOT	35	124	14861	-	98th. AVENUE, SURREY, B.C.
"	"	36	: 125	"	"
"	"	37	: 126	"	"
"	"	38	: 224	"	"
"	"	47	: 225	"	"
"	"	48	: 226	"	"

Signature
5/12/18

11427-2

STRATA PLAN N.W. 2754
PHASE 2

BUILDING EIGHT

SCALE - 1 : 200



ALL DISTANCES ARE IN METRES.

LEGEND

PT.S.L. DENOTES PART STRATA LOT.
m² SQUARE METRES.
L.C.P. LIMITED COMMON PROPERTY.



FIRST FLOOR

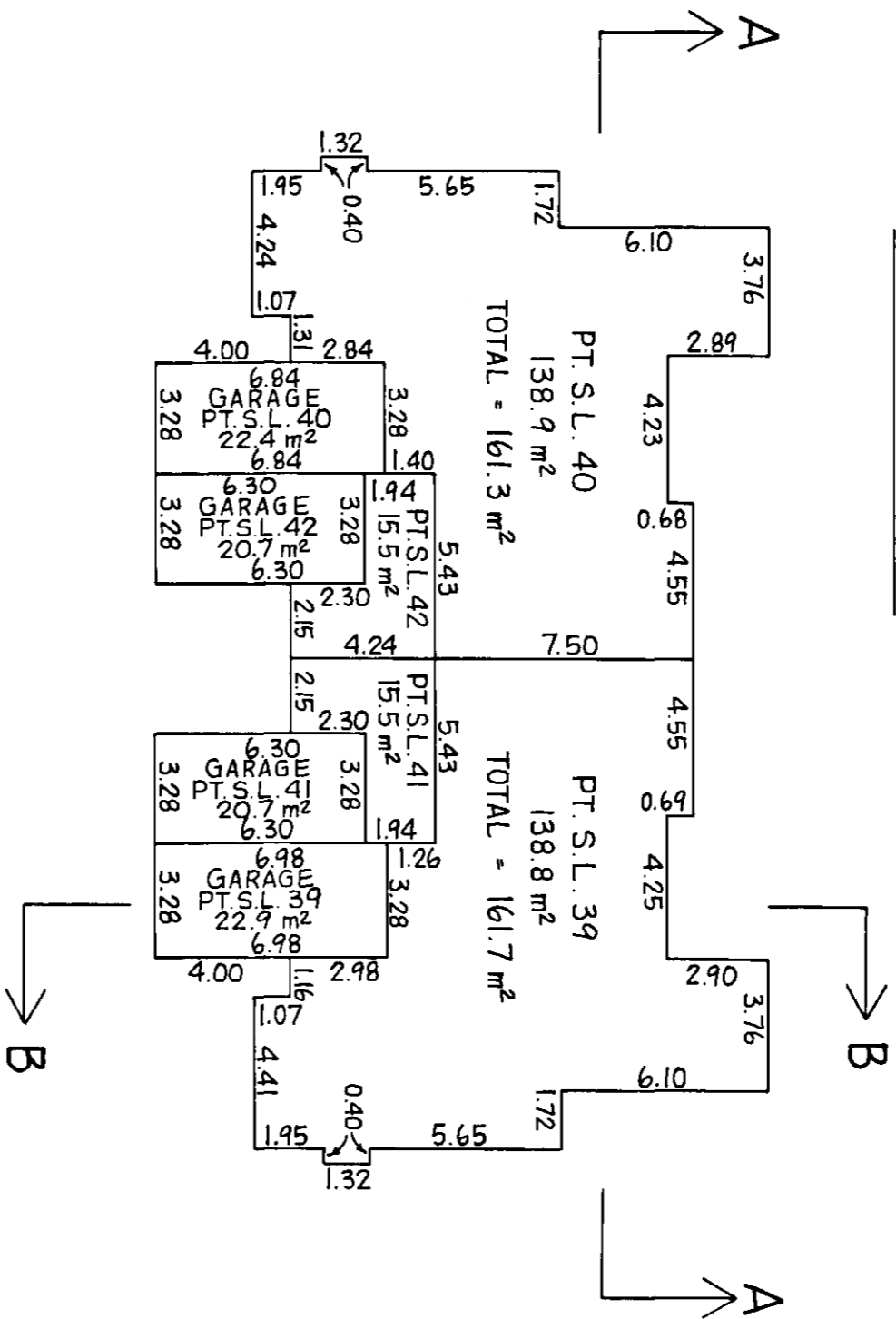

SECOND FLOOR

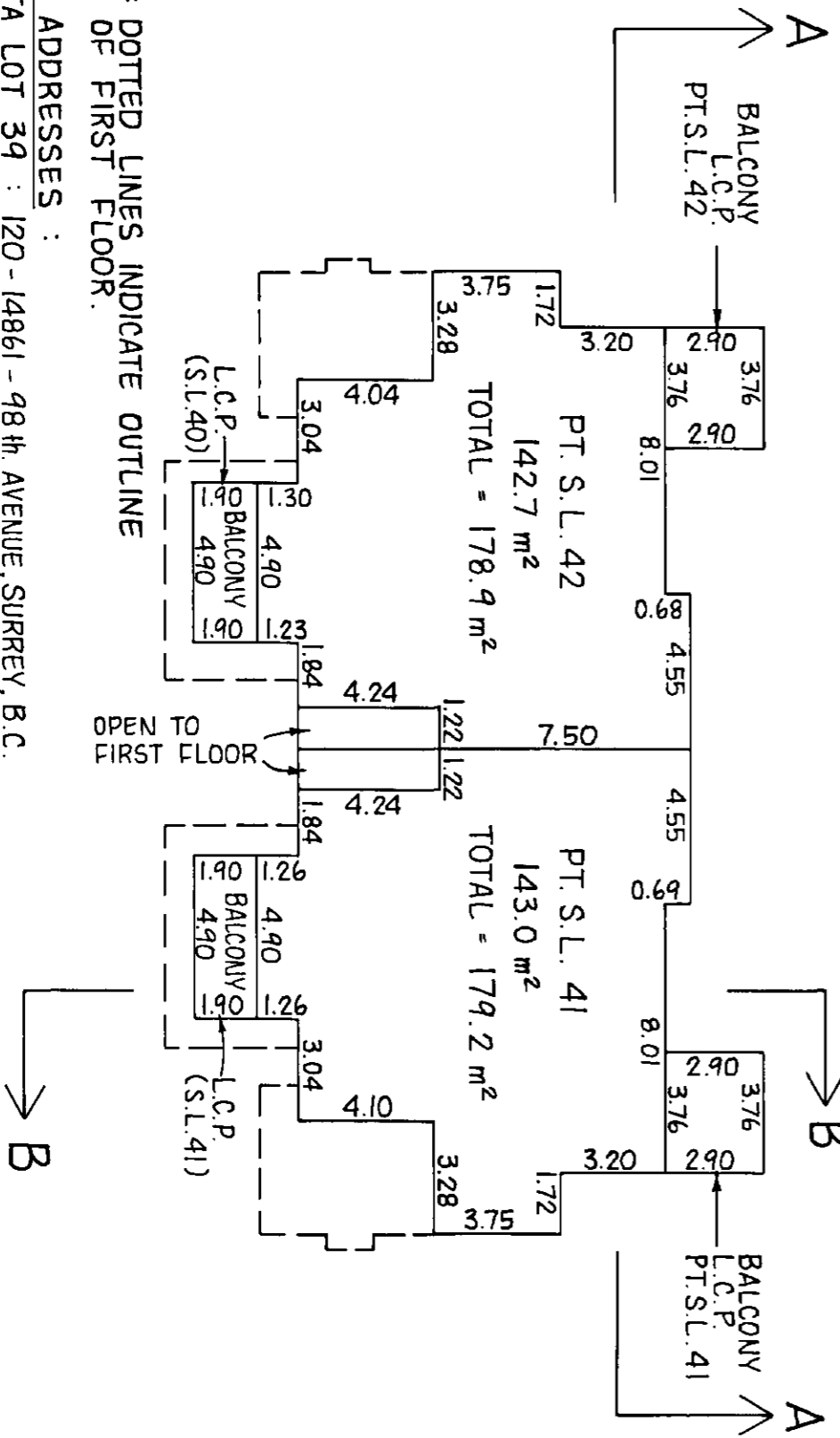

NOTE : DOTTED LINES INDICATE OUTLINE
OF FIRST FLOOR.

CIVIC ADDRESSES :

- STRATA LOT 39 : 120 - 14861 - 98th. AVENUE, SURREY, B.C.
- " 40 : 119 " " " " " " "
- " 41 : 220 " " " " " " "
- " 42 : 219 " " " " " " "

11427-2

Quigley
5/12/88

BUILDING EIGHT
ELEVATION SECTIONS

SHEET 12 OF 16 SHEETS
STRATA PLAN N.W. 2754
PHASE 2

SCALE - 1:200

LEGEND

PT. S.L. DENOTES PART STRATA LOT.
" " COMMON PROPERTY.



SECTION A-A

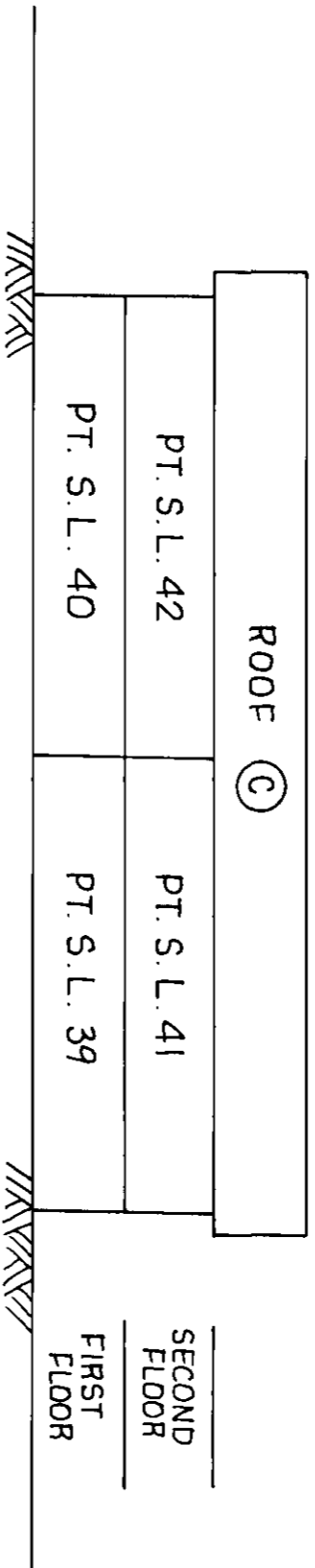

SECTION B-B

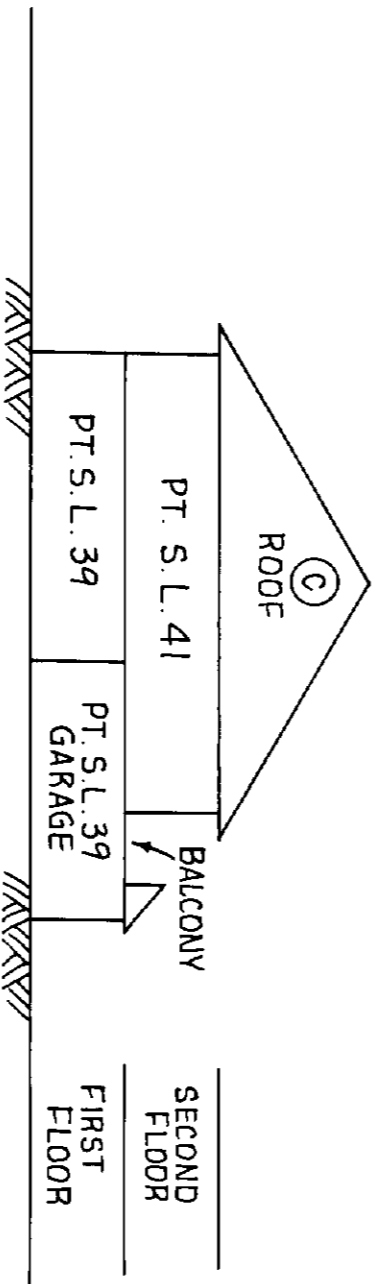

11427-2

Duns
5/12/88

BUILDING FOUR
ELEVATION SECTIONS

STRATA PLAN N.W. 2754
PHASE 2

SCALE - 1:200

LEGEND

PT. S.L. DENOTES PART STRATA LOT.
" " " " COMMON PROPERTY.
ⓐ

SECTION A-A

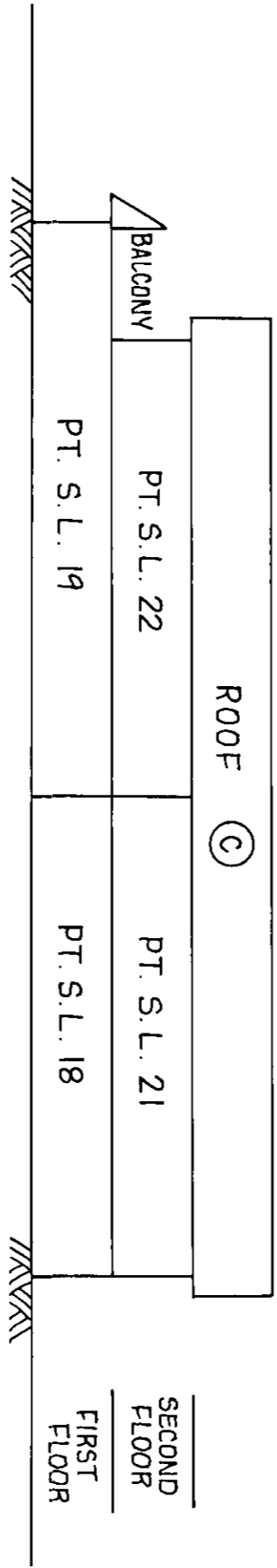

SECTION B-B

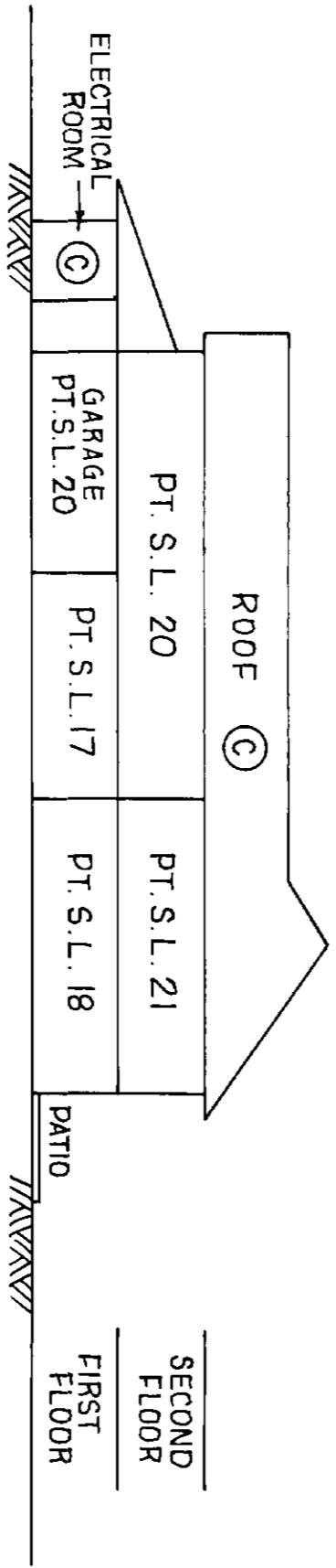

11427-2

Aug
5/2/88

BUILDING FIVE
ELEVATION SECTIONS

STRATA PLAN N.W. 2754
PHASE 2

SCALE - 1:200

LEGEND

PT.S.L. DENOTES PART STRATA LOT.
COMMON PROPERTY.
Ⓢ DENOTES COMMON PROPERTY.

SECTION A-A

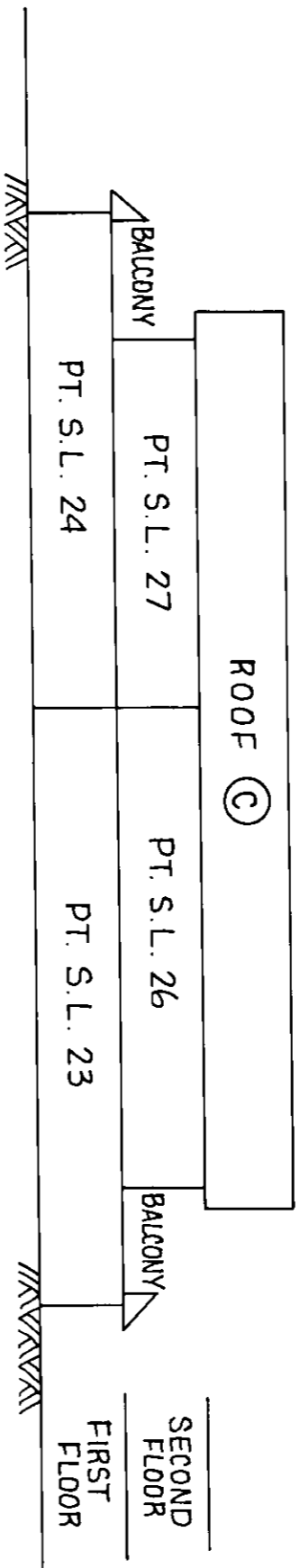

SECTION B-B

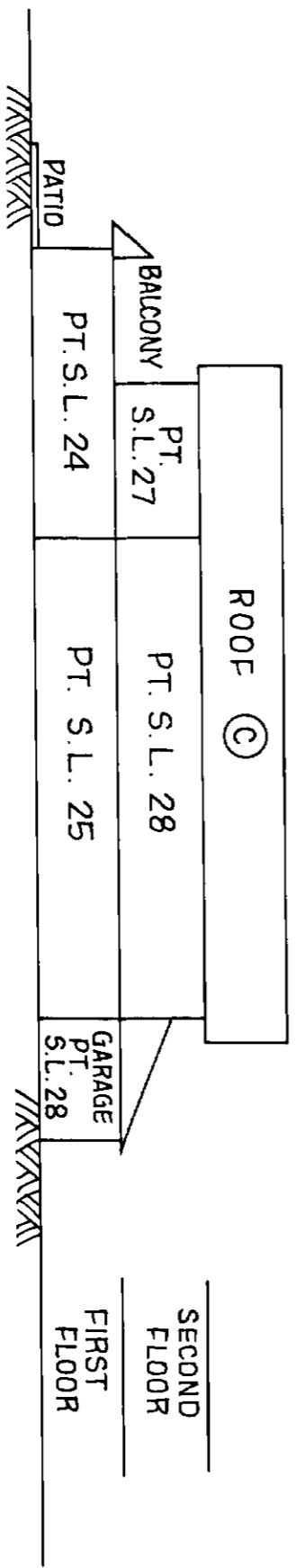

Handwritten signature
5/12/18

BUILDING SIX
ELEVATION SECTIONS

STRATA PLAN N.W. 2754
PHASE 2

SHEET 13 OF 16 SHEETS

SCALE - 1 : 200

LEGEND

PT. S.L. DENOTES PART STRATA LOT.
COMMON PROPERTY.

Ⓢ

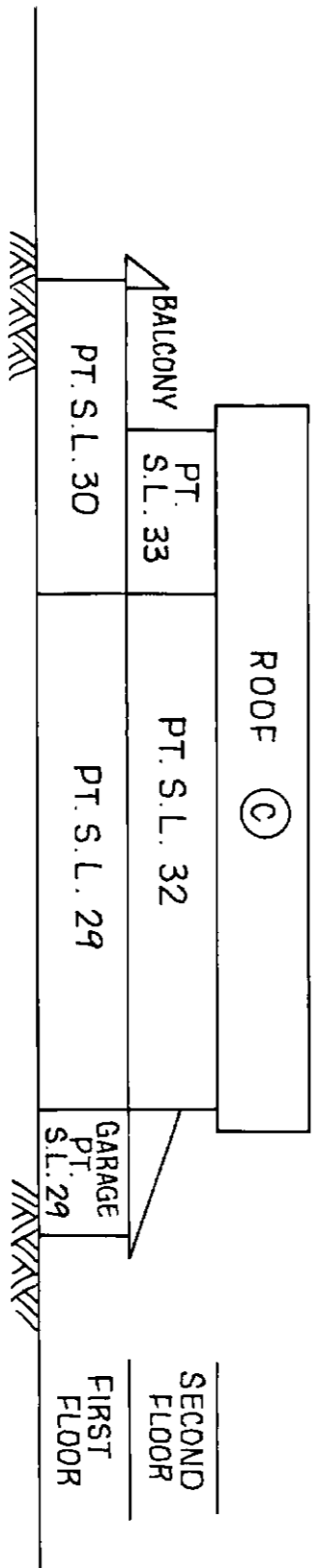
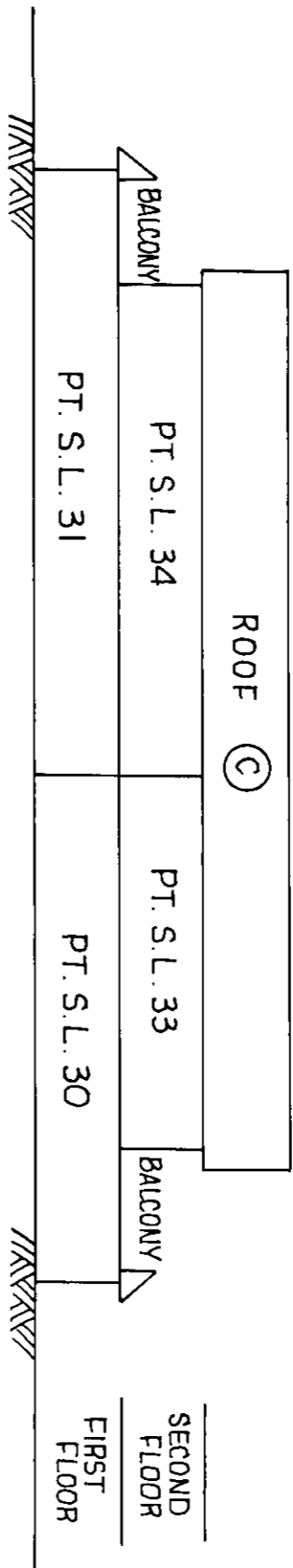

duo
5/2/88

11427-2

BUILDING SEVEN
ELEVATION SECTIONS

STRATA PLAN N.W. 2754
PHASE 2

SCALE - 1 : 200

LEGEND

PT. S.L. DENOTES PART STRATA LOT.
Ⓢ " COMMON PROPERTY.

SECTION A-A

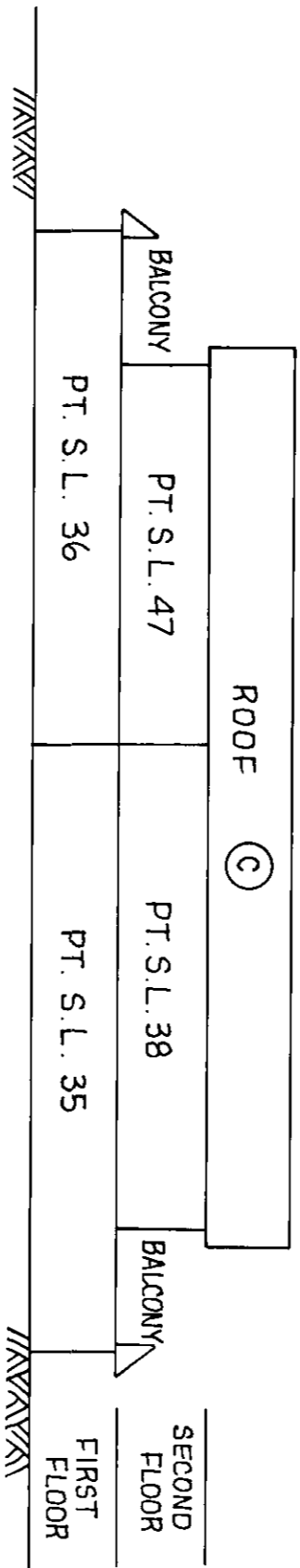

SECTION B-B

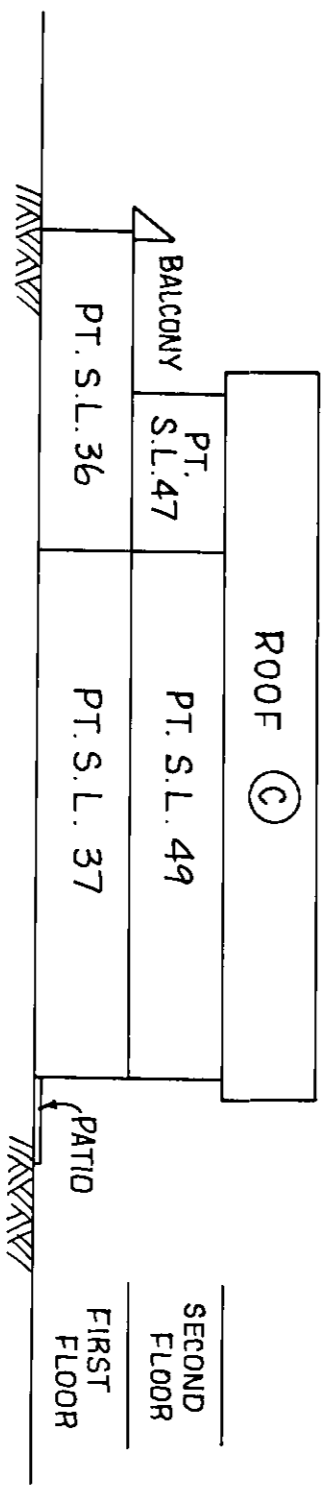

11427-2

Signature
5/12/88